

FileCenter Instructions

Tools needed: Finishing nail or nail punch; Hammer; Phillips screwdriver & Flat head screwdriver

NOTE:

These instructions are assuming that the FileCenter is being installed on existing shelving. If new shelving is being used, disregard Step 1.

Hardware Included:

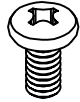

Phillips Screw



Flange Nut



Drive Rivet

- Step 1) Typical FileCenter installation is at the 4th tier location or directly above a posting shelf, however it may be used at any location (these instructions assume 4th tier location is used). Remove the 4th tier (from bottom) from the shelving unit. This will require removing 8 drive rivets (rivets to be removed are shown in left hand drawing marked with an (X)). Using either a nail or nail punch along with a hammer, drive the rivet pin through the drive rivet until it drops out. Use a flat head screwdriver to pry the rest of the rivet out. Remove the tier and replace with the FileCenter tier. Secure the FileCenter to the tier below it with 4 Phillips screws and nuts. Use the same holes as you would normally use to attach a standard tier.
- Step 2) Install the FileCenter as you would a standard tier. Be sure to slide FileCenter back so the interlocking tabs on the bottom of the FileCenter hook under the rear lip of the tier below. Secure the FileCenter to the tier below it with 4 Phillips screws and nuts. Use the same holes as you would normally use to attach a standard tier.
- Step 3) Replace the upper section of tiers making sure to slide the interlocking tabs on bottom of tiers under the rear lip of the FileCenter. Secure using 4 drive rivets. Use the same holes as you would normally use to attach a standard tier. Using a hammer drive the rivet pins into the body of the rivets until pins are flush with the top of the rivet head.

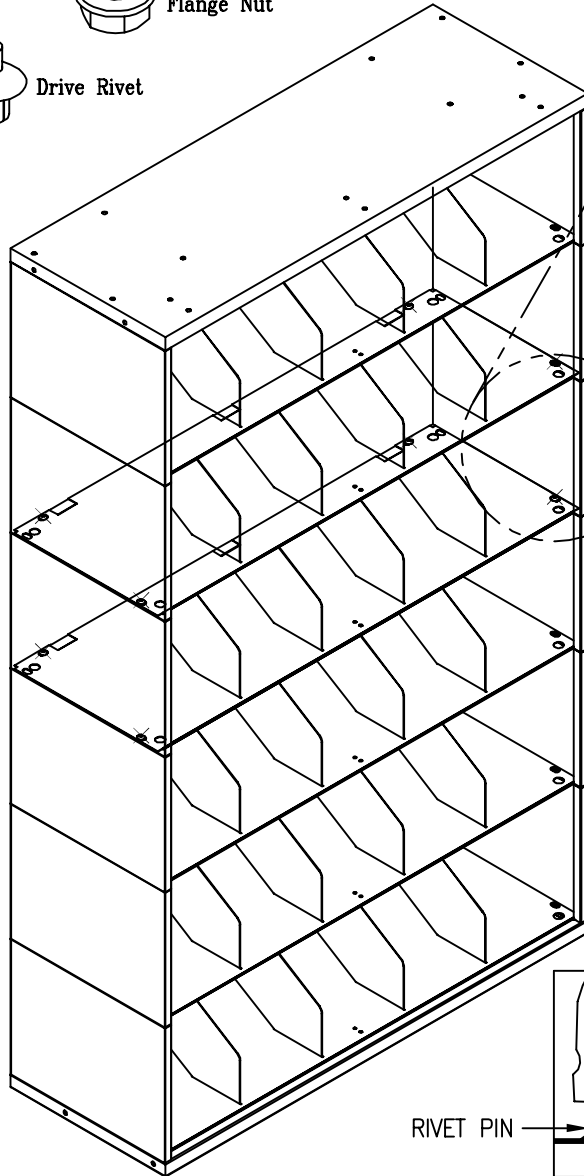

REMOVE THESE RIVETS (X)

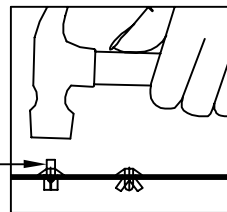

RIVET PIN

NOTE:

When securing with drive rivets, be sure rivet pin is flush with the top of the rivet head

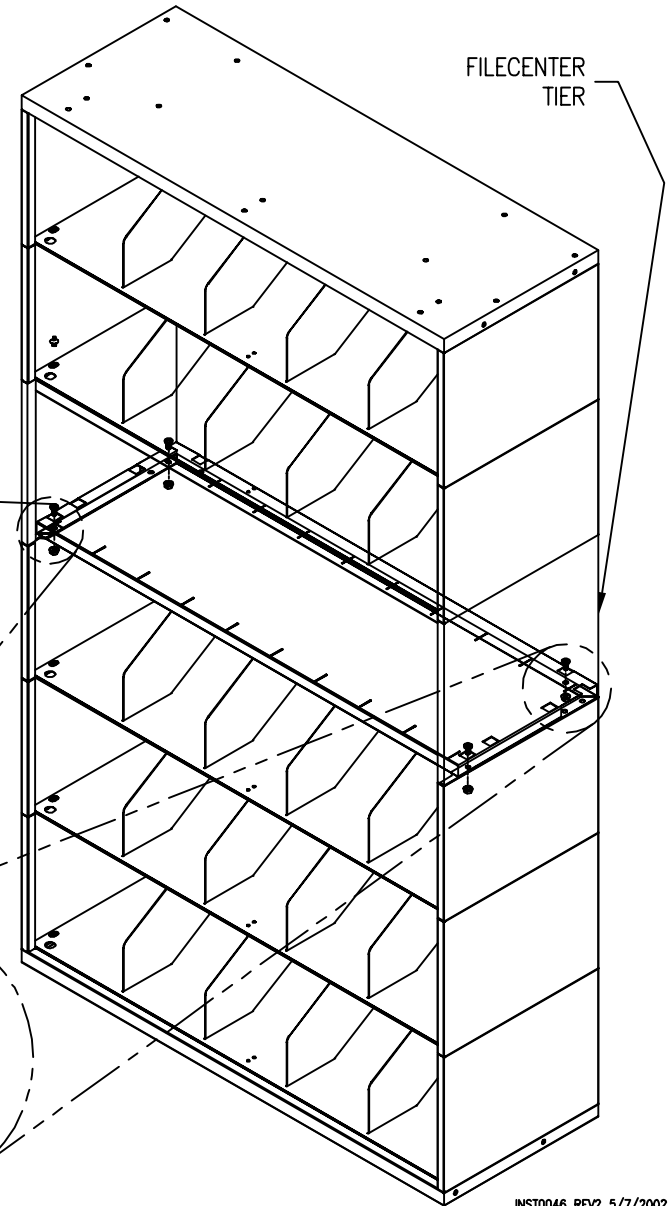

FILECENTER TIER

INSTALLING DIVIDERS (SHELF & VERTICAL DIVIDERS)

NOTE: SHELF DIVIDERS SHOWN

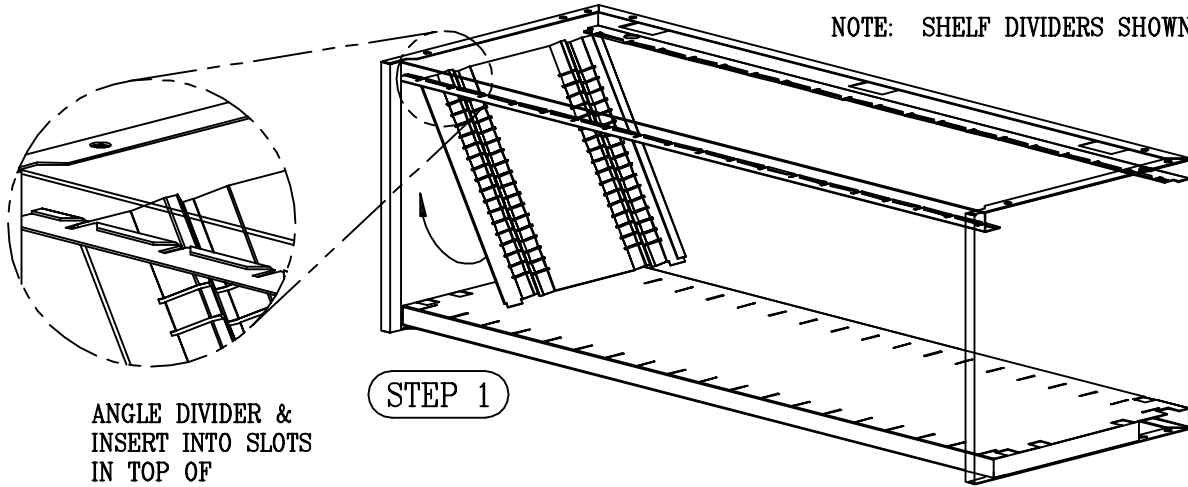

STEP 1

ANGLE DIVIDER & INSERT INTO SLOTS IN TOP OF FILECENTER

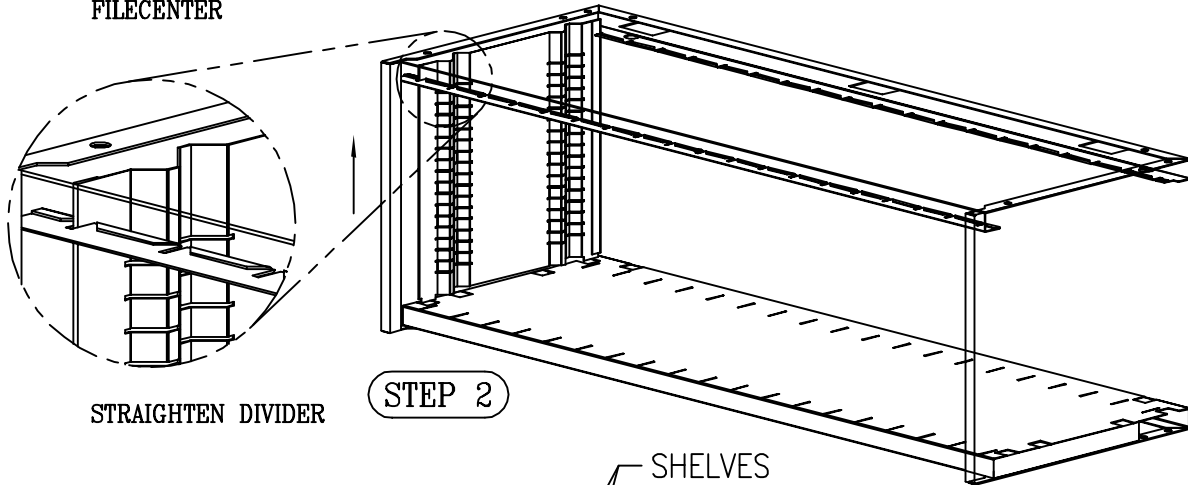

STEP 2

STRAIGHTEN DIVIDER

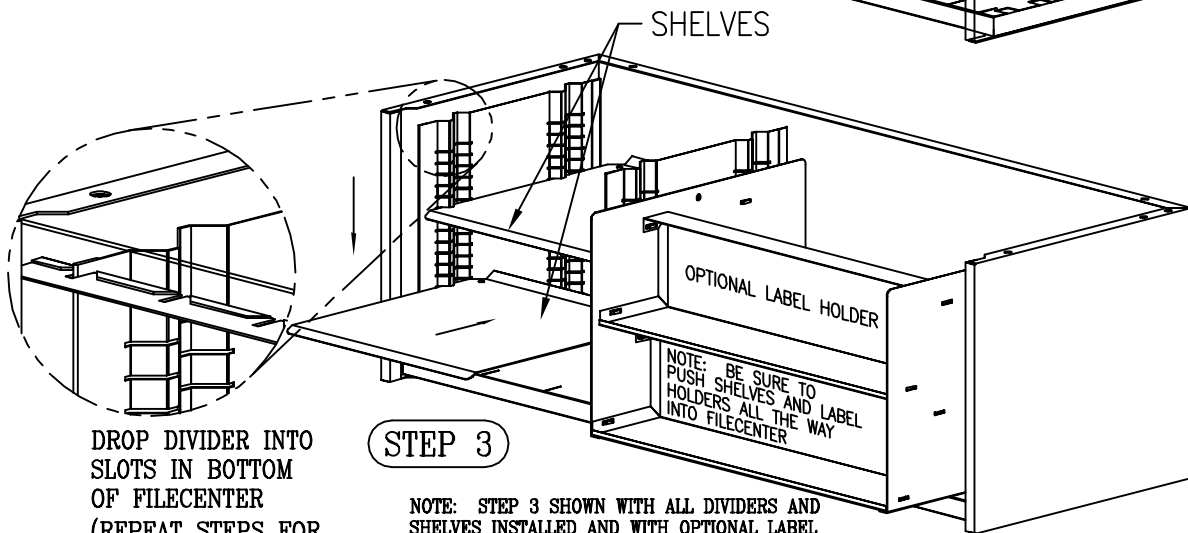

STEP 3

DROP DIVIDER INTO SLOTS IN BOTTOM OF FILECENTER (REPEAT STEPS FOR REMAINING DIVIDERS)

NOTE: STEP 3 SHOWN WITH ALL DIVIDERS AND SHELVES INSTALLED AND WITH OPTIONAL LABEL HOLDER (REFER TO RIGHTHAND ILLUSTRATION FOR SUGGESTED DIVIDER & LABEL HOLDER POSITIONING)

