

MINI VU-STAK TAMBOUR DOOR INSTRUCTIONS

**PLEASE OPEN ALL BOXES & CHECK TO MAKE SURE
YOU HAVE ALL PIECES REQUIRED
READ ALL INSTRUCTIONS BEFORE STARTING**

Tools required for assembly:

(Drill gun not shown)

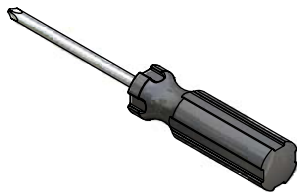

Phillips Head
Screwdriver



7/16" Wrench

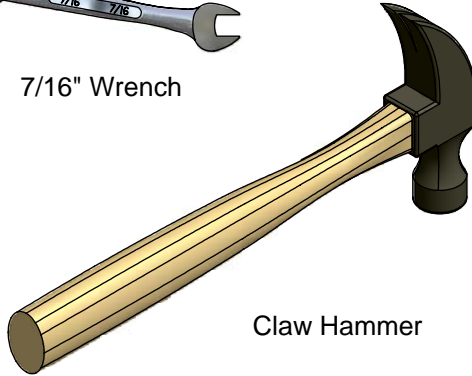

Claw Hammer

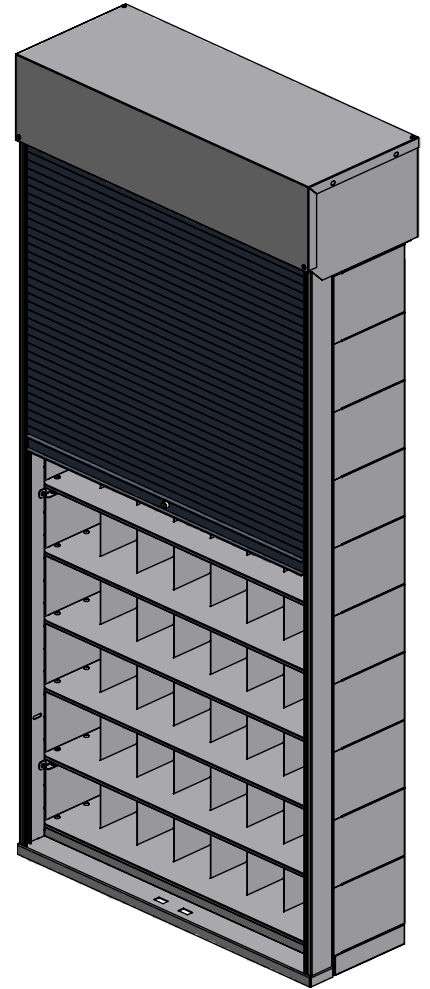

Hardware included:

(Shown full size)

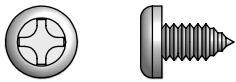

#10 x 3/8" Phillips Pan
Head Sheet Metal Screw



#8 x 3/8" Phillips Pan
Head Tek Screw

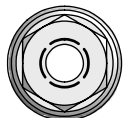

1/4-20 Flanged Hex Nut



1/4-20 x 1/2" Phillips Pan
Head Machine Screw

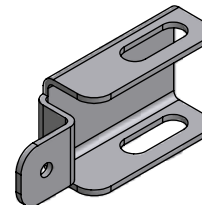
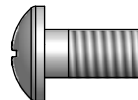

Upright Bracket
(Not Shown Full Size)

MINI VU-STAK TAMBOUR DOOR INSTRUCTIONS

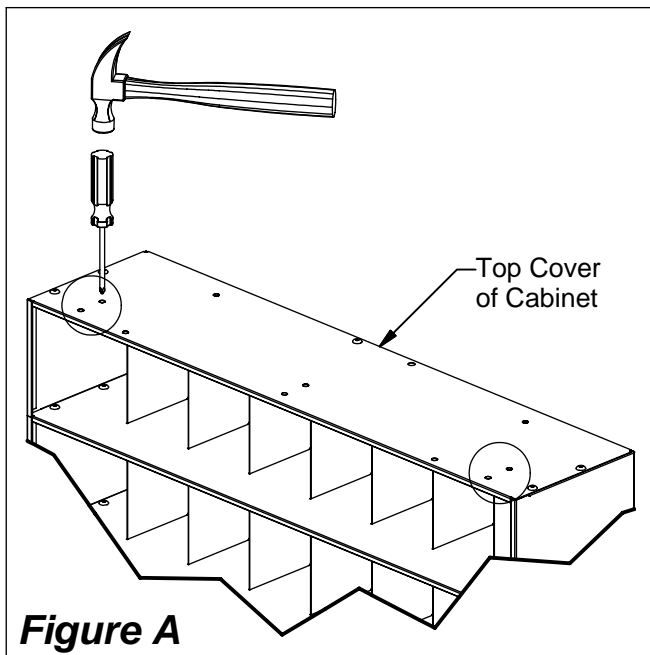

Step 1: Before beginning to assemble any tambour parts, four knockouts need to be knocked out of the top cover of the shelving. Use a hammer and a screwdriver to remove knockouts as shown in **Figure A**.

Step 2: Remove top rivet, second from bottom rivet, and a rivet from middle on each side (see **Figure B**). Use a nail and hammer to remove rivets. To do this, place pointed tip of nail directly in center of rivet (see **Detail C**). Now hit head of nail with a hammer and pin of rivet will eject out bottom.

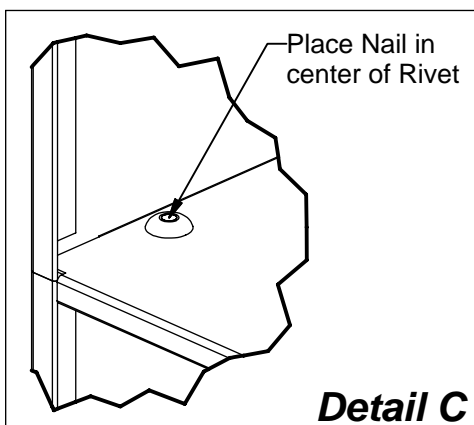
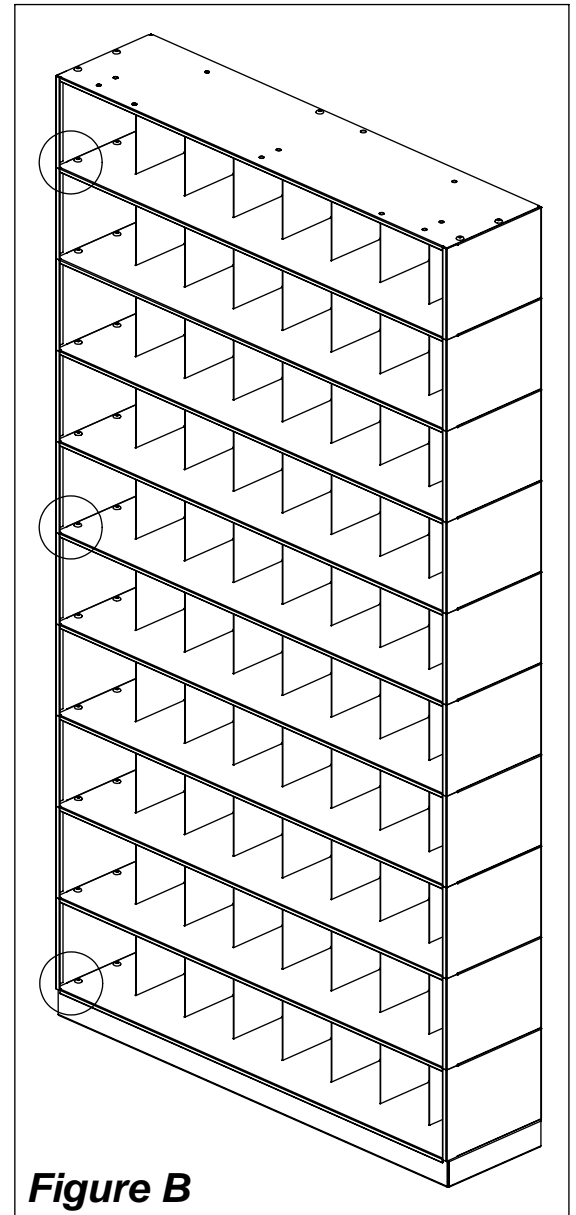

MINI VU-STAK TAMBOUR DOOR INSTRUCTIONS

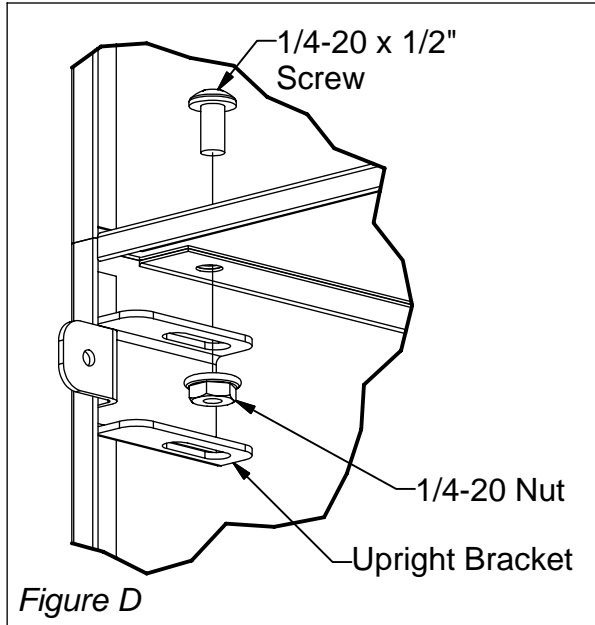

STEP 3: Fasten upright brackets to shelving by attaching them where rivets were removed (see *Figure D*). Use 1/4-20 x 1/2" nuts and bolts.

STEP 4: Place door frame bottom in front of shelving (see *Figure E*).

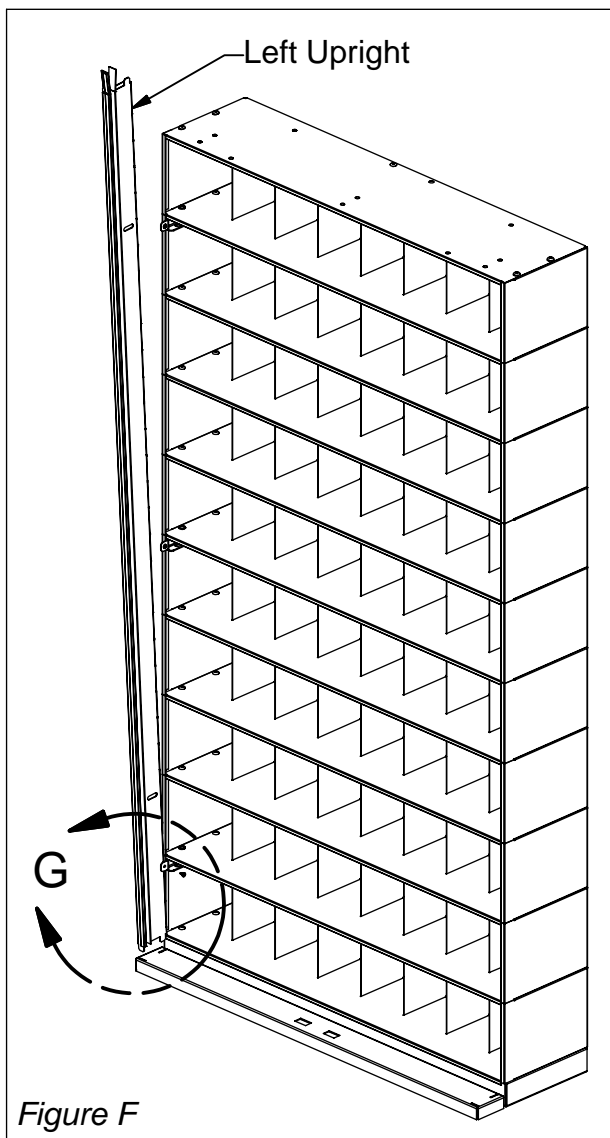
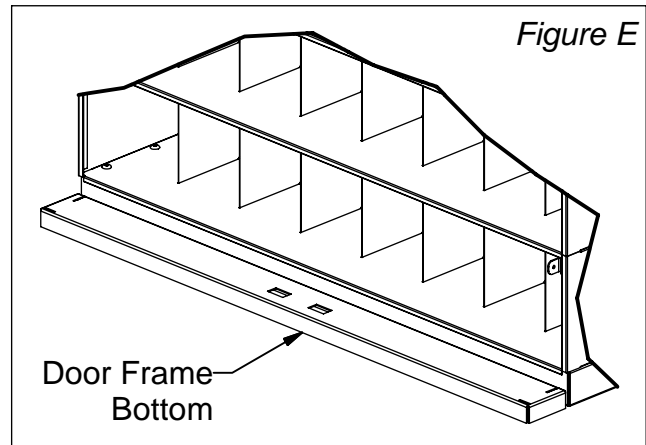

STEP 5: Insert left upright into slots on door frame bottom (see *Figure F*). Use #8 x 3/8" tek screws to fasten upright brackets to left upright (see *Figure G*). Repeat for right upright.

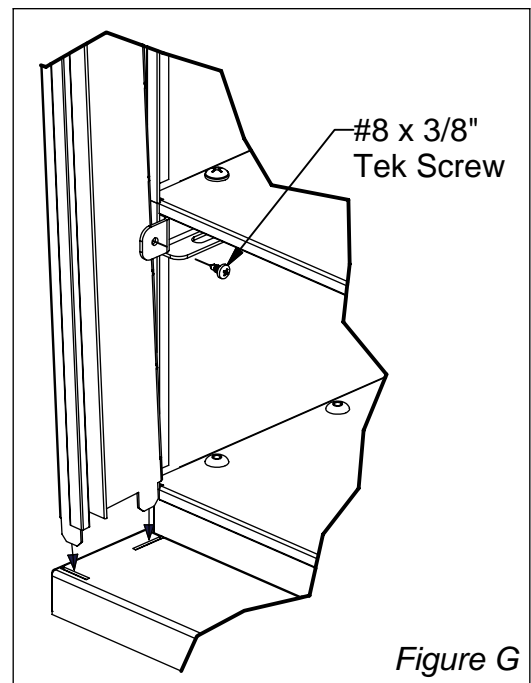

MINI VU-STAK TAMBOUR DOOR INSTRUCTIONS

STEP 6: Place tambour box on top of shelving & be certain that uprights are aligned with openings in bottom of box. See *Figure H*.

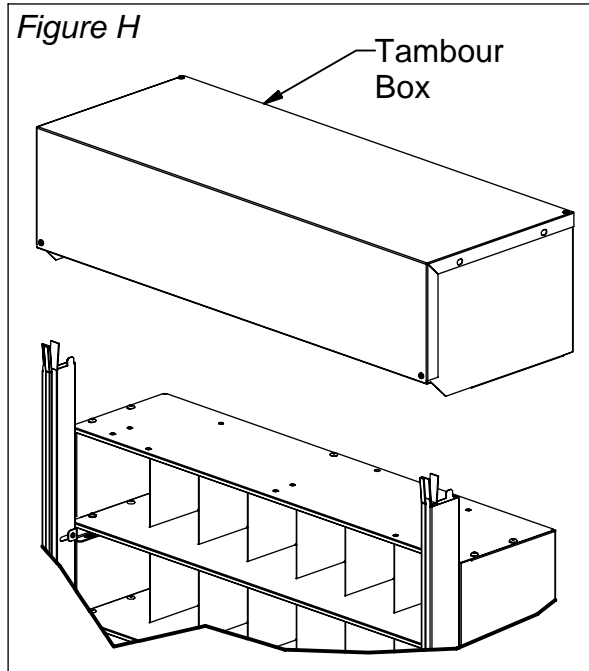

STEP 7: Remove four #10 x 3/8" Phillips Pan Head Sheet Metal Screws from Tambour Box. See *Figure J*.

STEP 8: Remove Top Cover from Tambour Door Box. See *Figure K*.

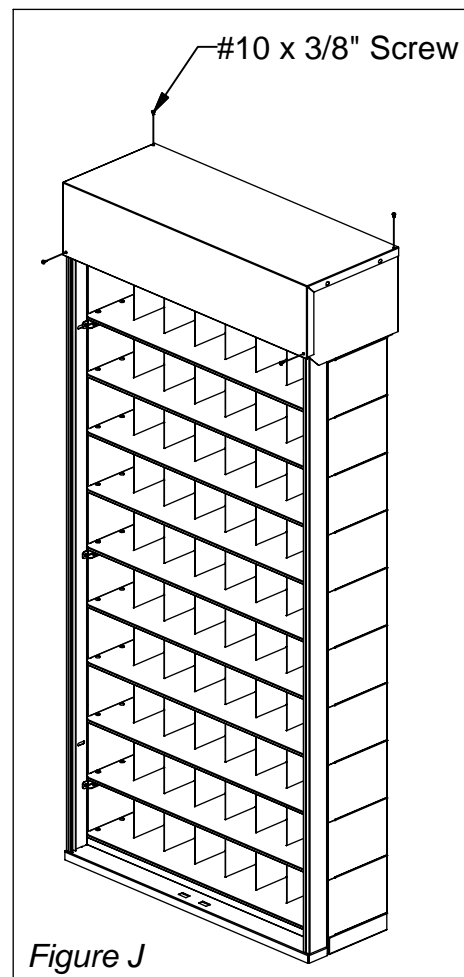
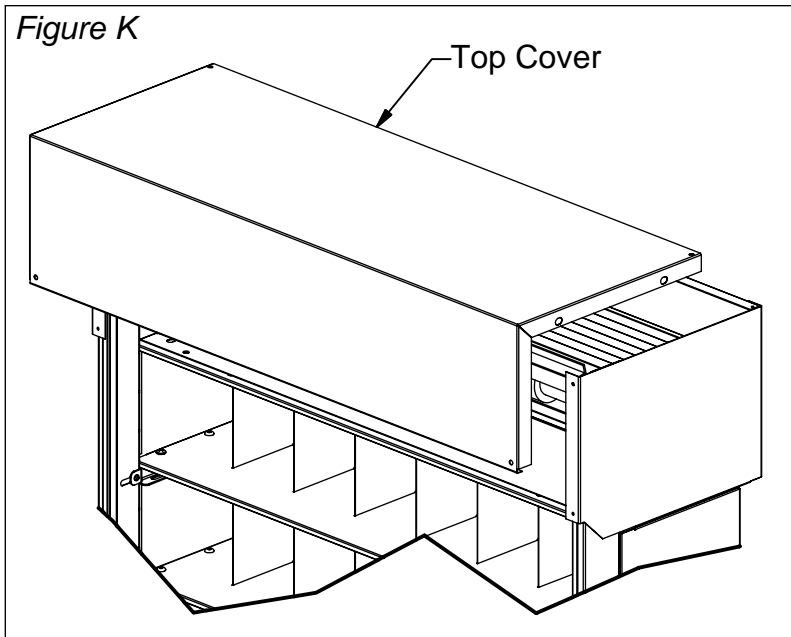
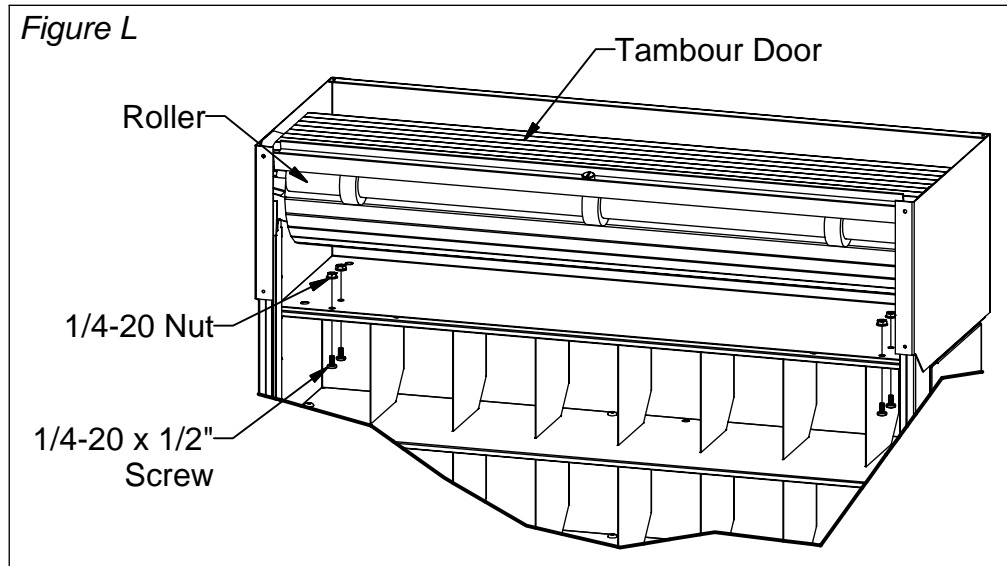

Figure J



MINI VU-STAK TAMBOUR DOOR INSTRUCTIONS

STEP 9: Remove packaging materials in Tambour Box. Use four 1/4-20 x 1/2" Phillips Pan Head Machine Screws & Flanged Hex Nuts to secure the Tambour Box to the shelving. See *Figure L*.



STEP 10: Align Tambour Door within Plastic Track of Uprights & pull door down. See *Figure M*. At this point, door should fully extend & retract smoothly.

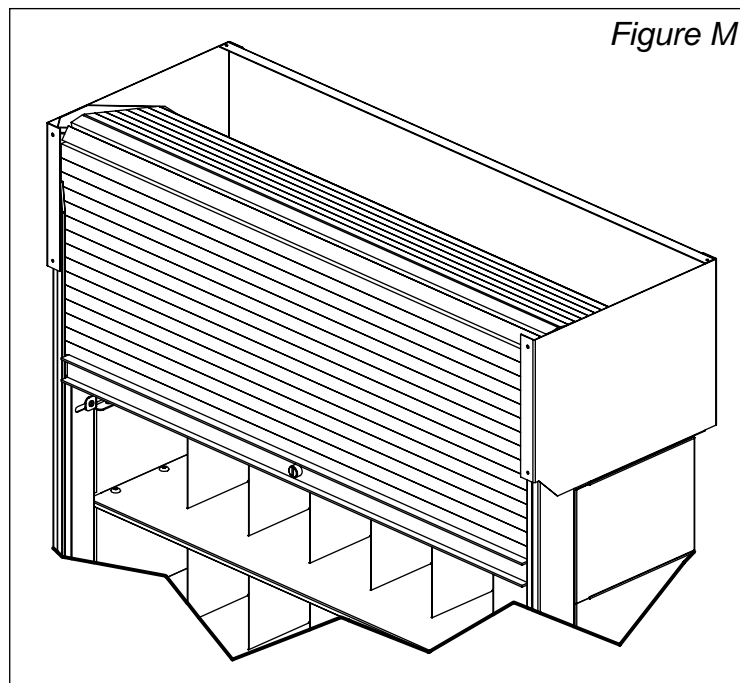

MINI VU-STAK TAMBOUR DOOR INSTRUCTIONS

STEP 11: Install Top Cover with four #10 x 3/8" Phillips Pan Head Sheet Metal Screws. See *Figure N*.

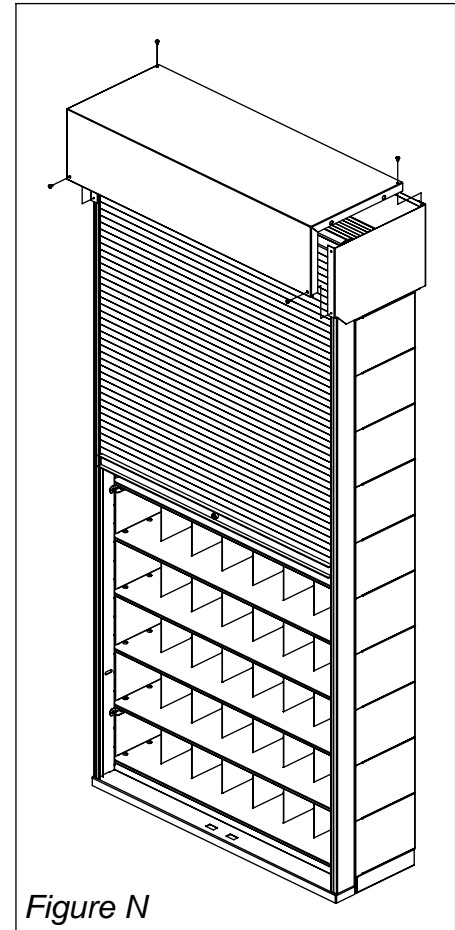
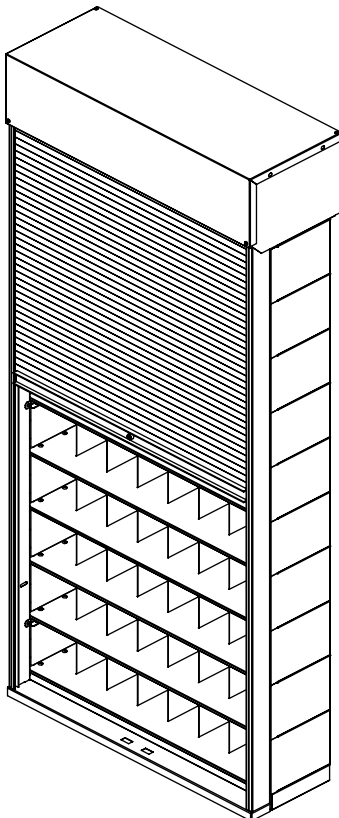

Figure N

Locking the unit

Pull tambour door down until bottom of door is against the bottom door frame. Insert key & turn to lock tambour door unit. (Two keys are included with tambour door unit.)

If you need assembly assistance, please contact Customer Service at:
1-866-217-0330 (Monday thru Friday 8:00 AM - 5:00 PM E.S.T.)