

TambourDoor Instructions

Please choose the type of shelving that you want the TambourDoor installed on.

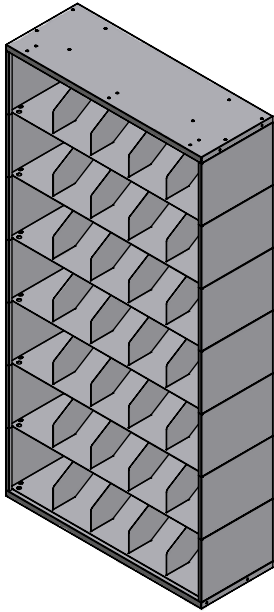

*Start on Page 2 for
ThinStak Shelving*

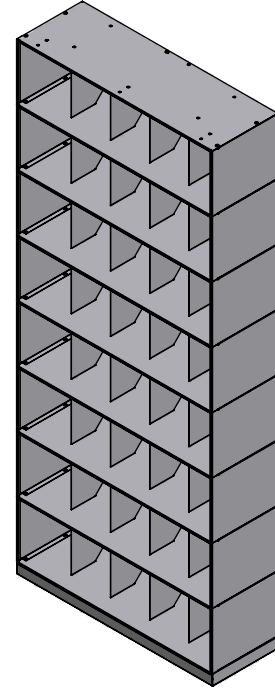

*Start on Page 7 for
Vu-Stak Shelving*

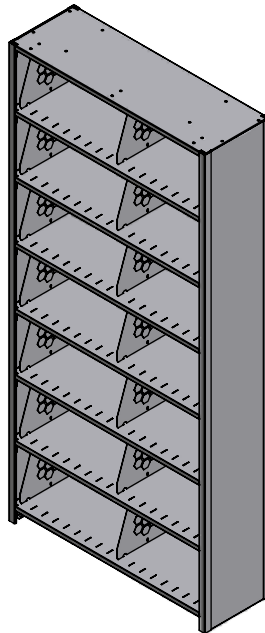

*Start on Page 12 for
4Post Shelving*

Troubleshooting & Normal Operating Instructions start on page 17.

Please Note: Not all hardware will be used during installation.

ThinStak TambourDoor Instructions

Step 1: Four knockouts need to be removed from the top of the shelving. Use a hammer & screwdriver to aid in removal of knockouts. Knockouts are designated in **Figure A**.

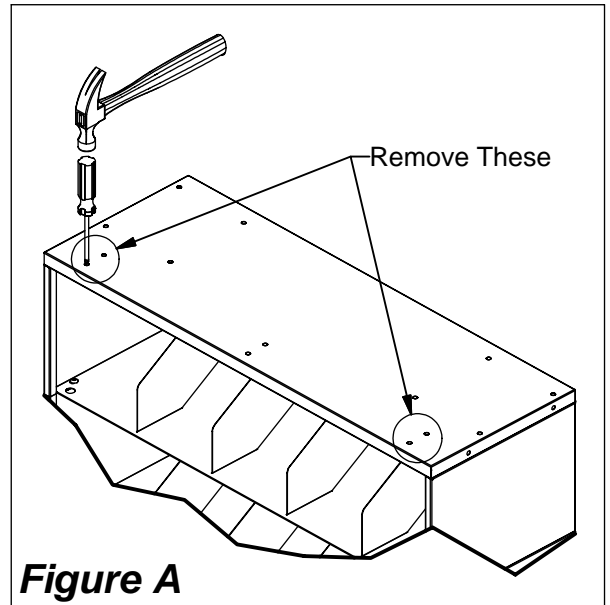

Step 2: Position Door Frame Bottom in front of shelving as shown in **Figure B**.

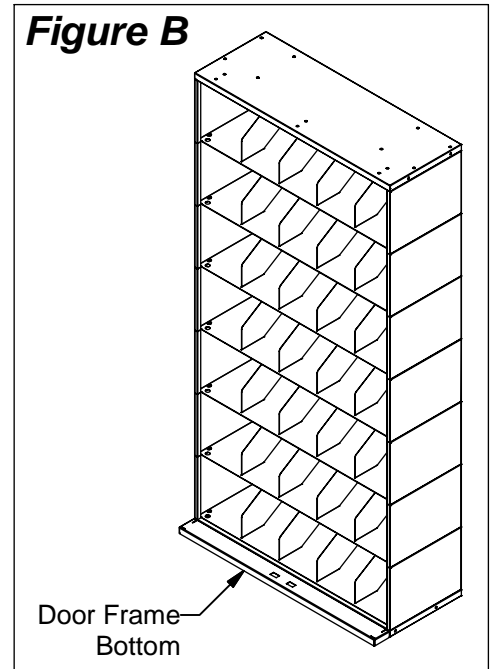

Step 3: Position Left Upright as shown in **Figure C**. Tabs of Upright should fit into slots on Door Frame Bottom.

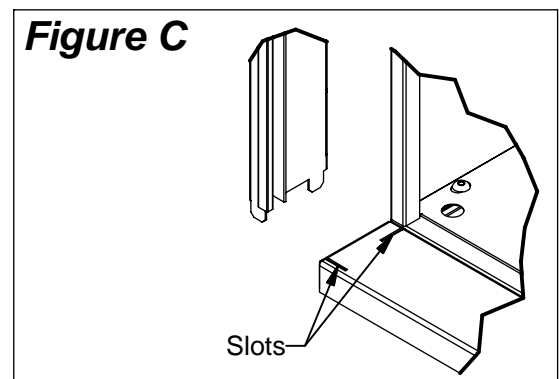

ThinStak TambourDoor Instructions

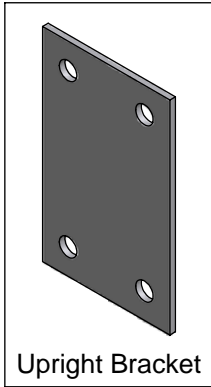

Step 4: Three Upright Brackets have to be installed for each Upright to fasten it to shelving. Use four #8 x 3/8" Phillips Pan Head Tek Screws to fasten a Bracket to the Upright & shelving as shown in **Detail E**. Upright Brackets should be spaced with one at the top, middle, & bottom as shown in **Figure D**.



Step 5: Repeat **Steps 3 & 4** for Right Upright.

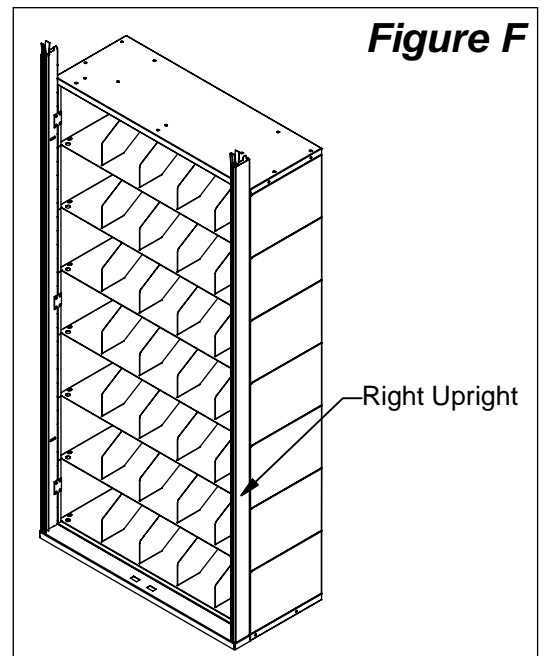
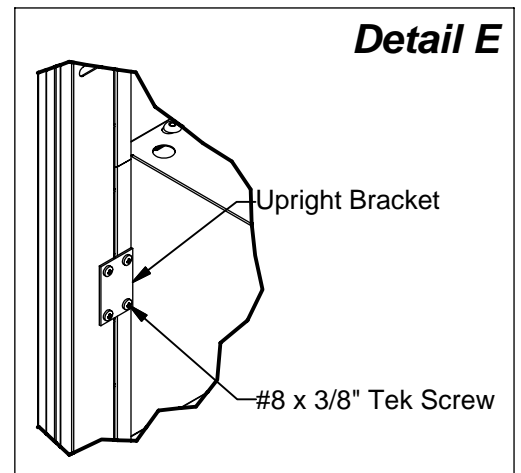
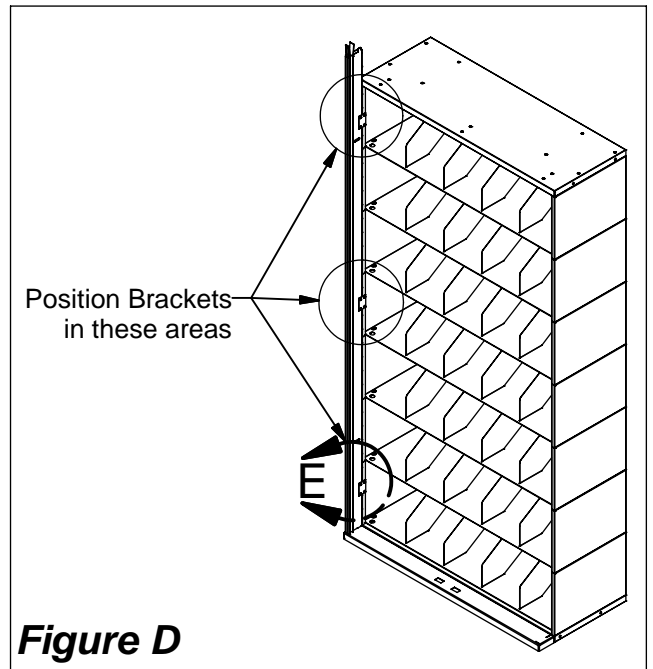

ThinStak TambourDoor Instructions

Step 6: Position Tambour Door Box on top of shelving & be certain that Uprights are aligned within openings in bottom of box. See **Figure G**.

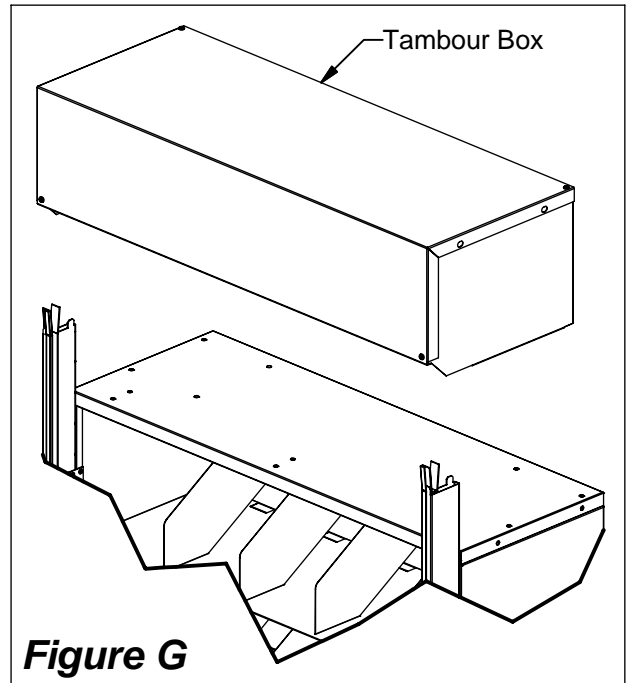

Step 7: Remove four #10 x 3/8" Phillips Pan Head Sheet Metal Screws from Tambour Door Box. See **Figure H**.

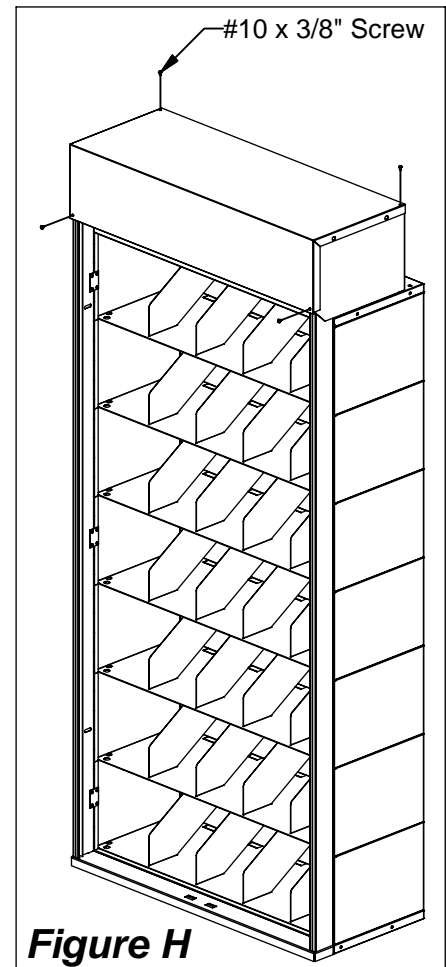
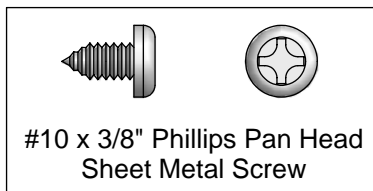

ThinStak TambourDoor Instructions

Step 8: Remove Top Cover from Tambour Door Box. See **Figure J**.

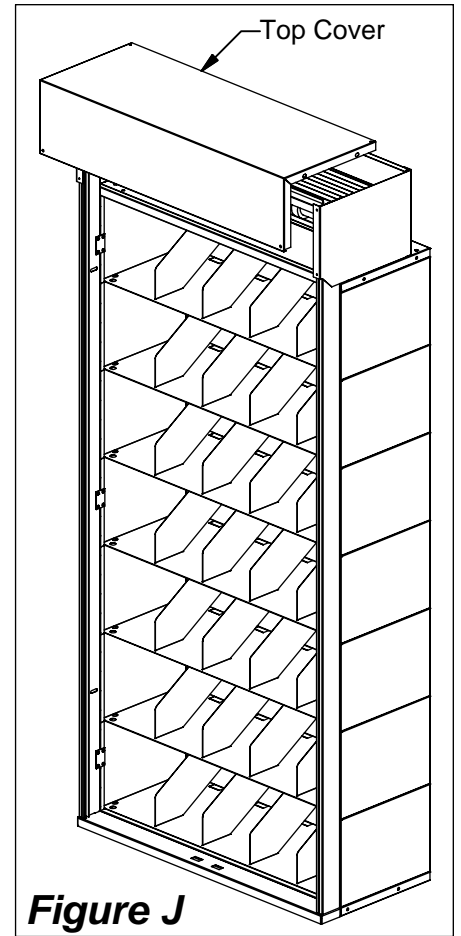

Step 9: Remove packaging materials in Tambour Box. Use four 1/4-20 x 1/2" Phillips Pan Head Machine Screws & Flanged Hex Nuts to secure the Tambour Box to the shelving. See **Figure K**.

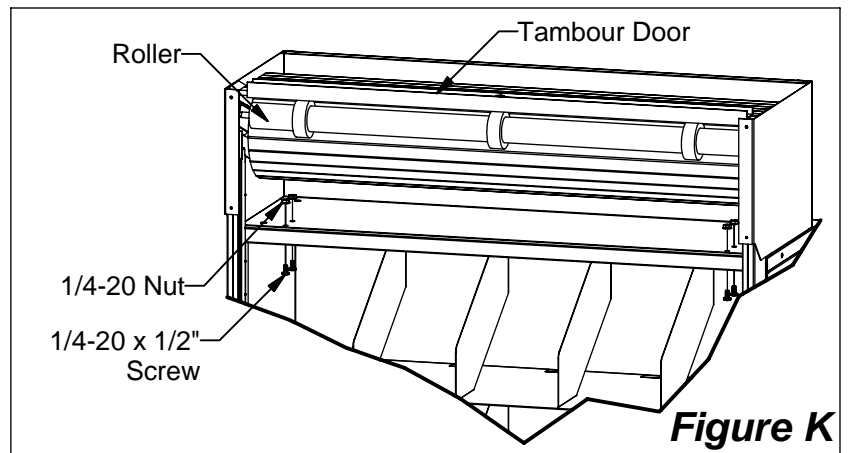
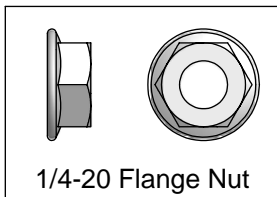
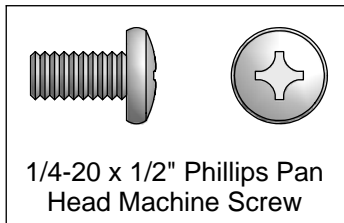

ThinStak TambourDoor Instructions

Step 10: Align Tambour Door within Plastic Track of Uprights & pull door down. See **Figure L**. At this point, door should fully extend & retract smoothly. If door does not retract fully, refer to page 17 of Troubleshooting Section to verify door is being held in housing correctly.

Step 11: Check for smooth operation of door. Should door bind, jam or seems to be catching, refer to Troubleshooting Section on page 17.

Step 12: Install Top Cover with four #10 x 3/8" Phillips Pan Head Sheet Metal Screws. See **Figure M**.

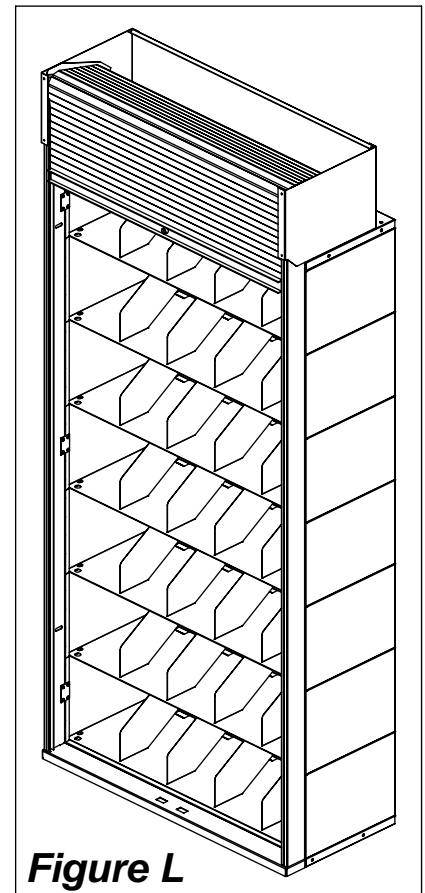

Figure L

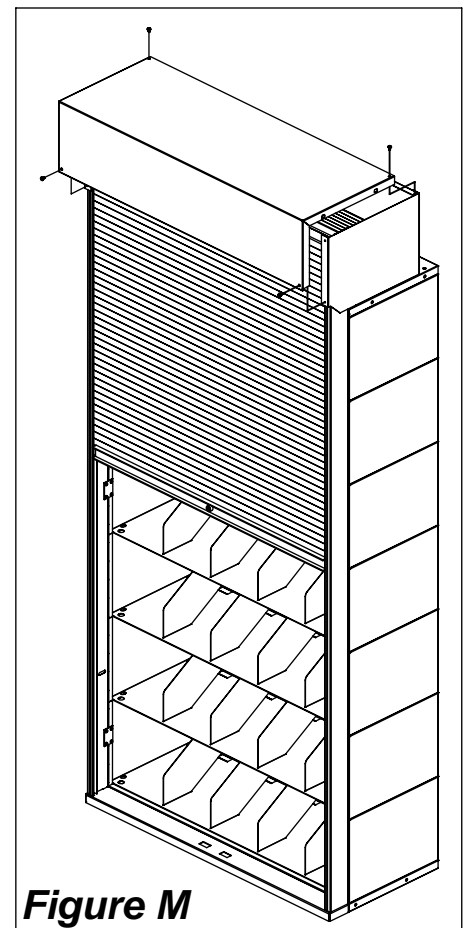
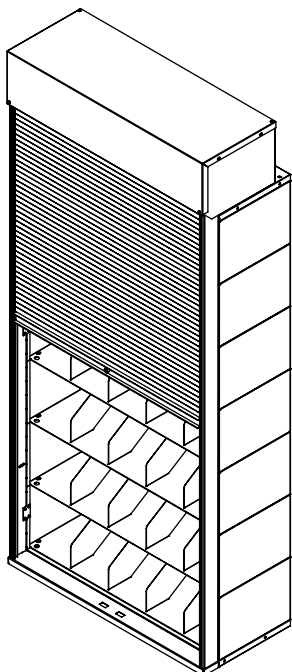

Figure M



For assembly assistance please call
1-866-217-0330.

Vu-Stak Tambour Door Instructions

Step 1: Four knockouts need to be removed from the top of the shelving. Use a hammer & screwdriver to aid in removal of knockouts. Knockouts are designated in **Figure A**.

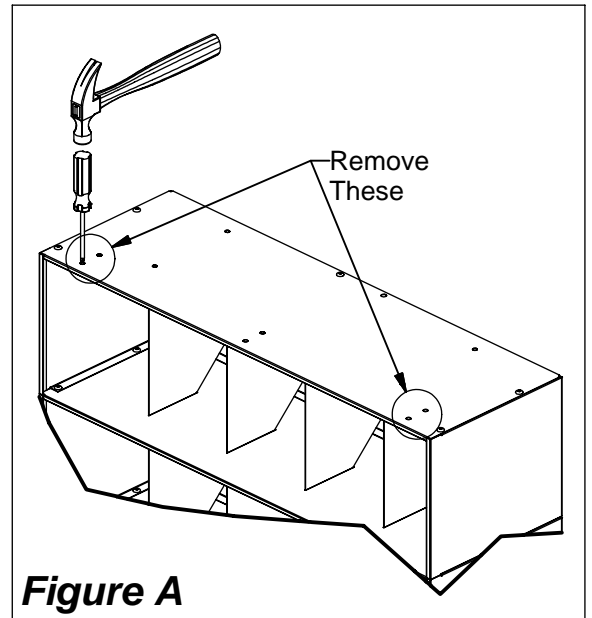

Step 2: Position Door Frame Bottom in front of shelving as shown in **Figure B**.

Step 3: Remove the top rivet, second from the bottom rivet, & a rivet from the middle. Both sides must have rivets removed. Use a nail & hammer to remove the rivets. To do this, place the pointed tip of the nail directly in the center of the rivet. Now hit the head of the nail with a hammer & the pin of the rivet will eject out the bottom. See **Figure B** & **Detail C**.

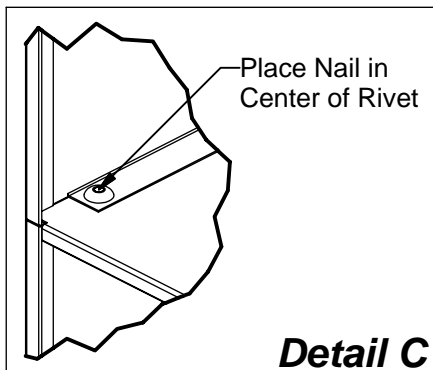
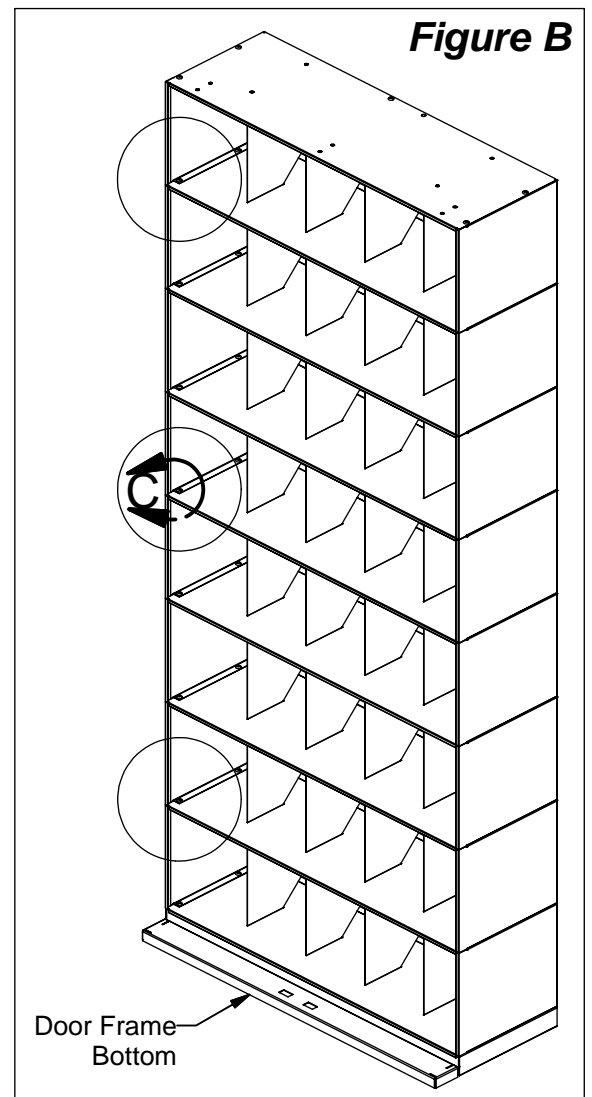

Vu-Stak Tambour Door Instructions

Step 4: Fasten three Upright Brackets to shelving by attaching them where rivets were removed in **Step 3**. Use 1/4-20 x 1/2" Phillips Pan Head Machine Screws & Flanged Hex Nuts. See **Figure D** & **Detail E**.

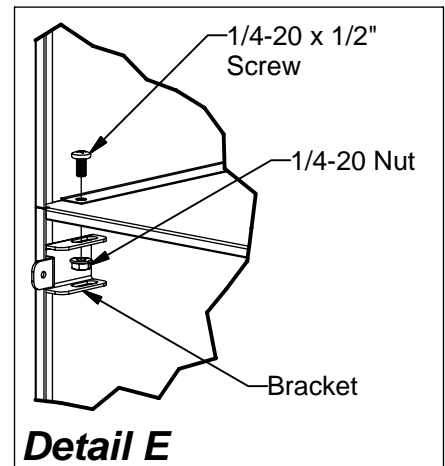
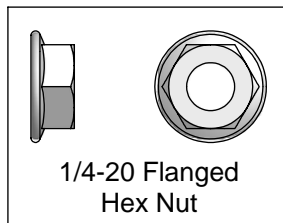
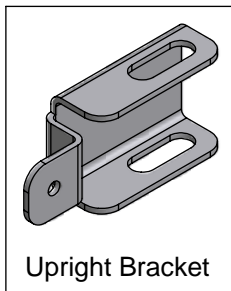
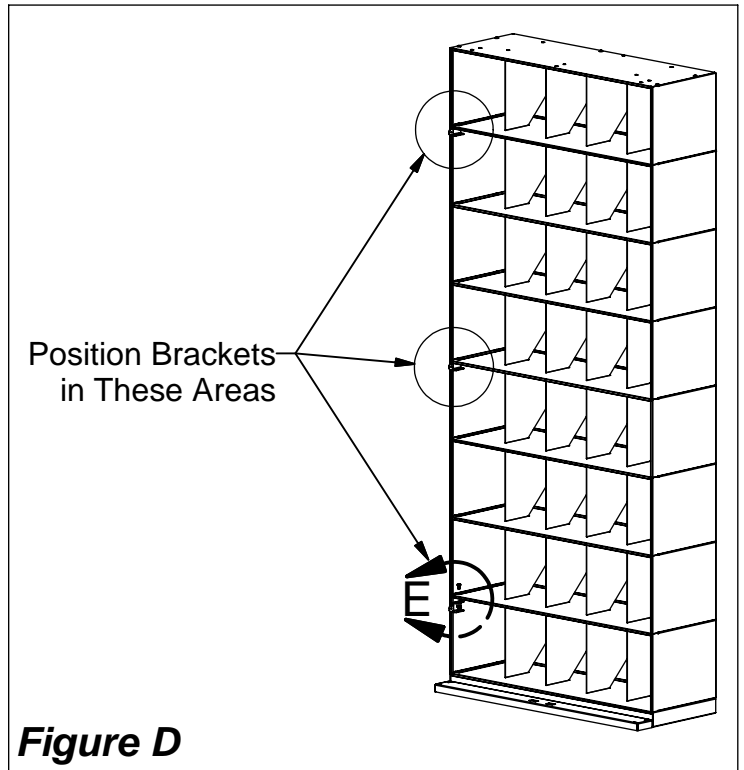
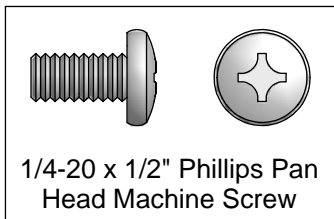

Step 5: Position Left Upright as shown in **Figure F**. Tabs of Upright should fit into slots on Door Frame Bottom.

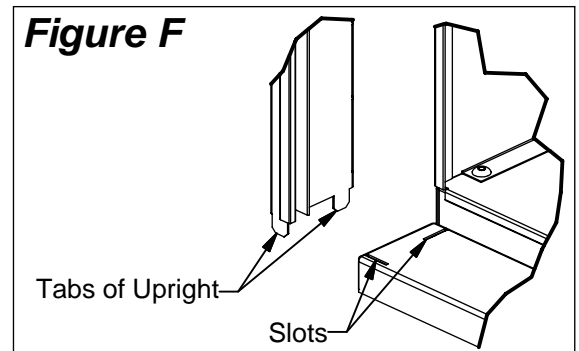

Vu-Stak Tambour Door Instructions

Step 6: Fasten the Upright Brackets to the Upright using #8 x 3/8" Tek Screws. See **Figure G**.

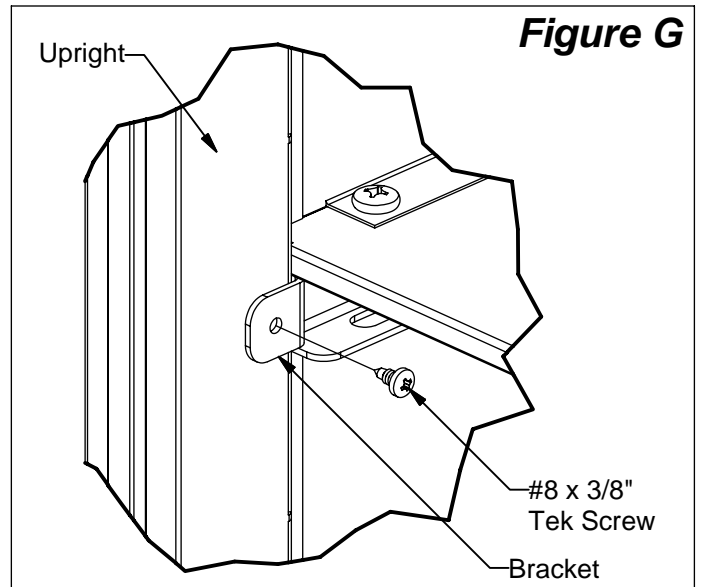
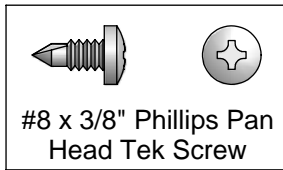

Step 7: Repeat **Steps 4-6** for installing the Right Upright.

Step 8: Position Tambour Door Box on top of shelving & be certain that Uprights are aligned within openings in bottom of box. See **Figure J**.

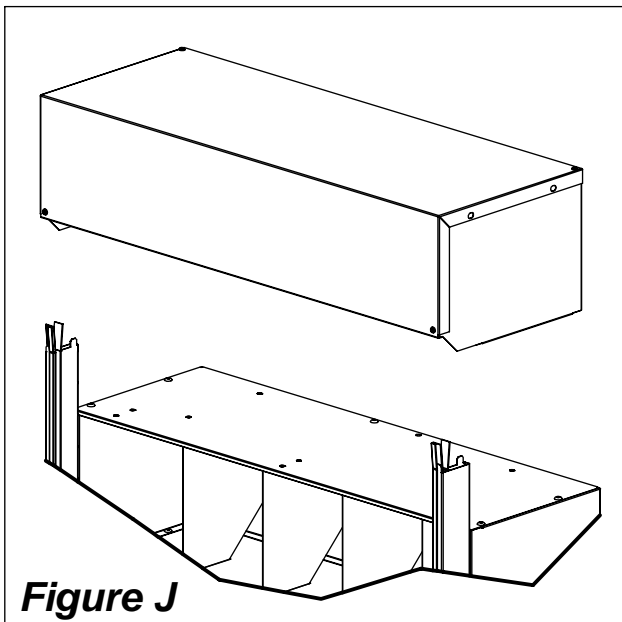
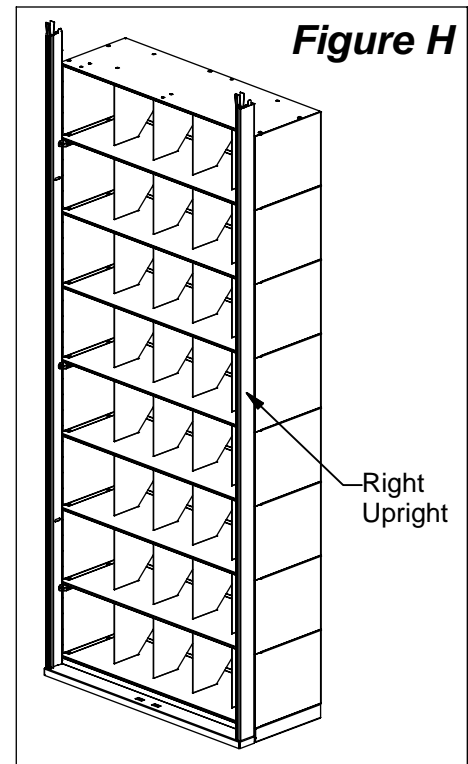

Vu-Stak TambourDoor Instructions

Step 9: Remove four #10 x 3/8" Phillips Pan Head Sheet Metal Screws from Tambour Door Box. See **Figure K**.

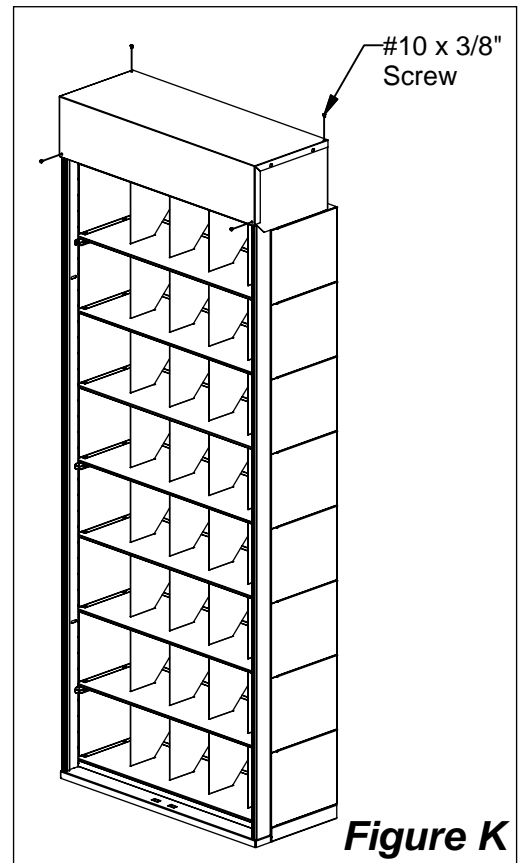

Step 10: Remove Top Cover from Tambour Door Box. See **Figure L**.

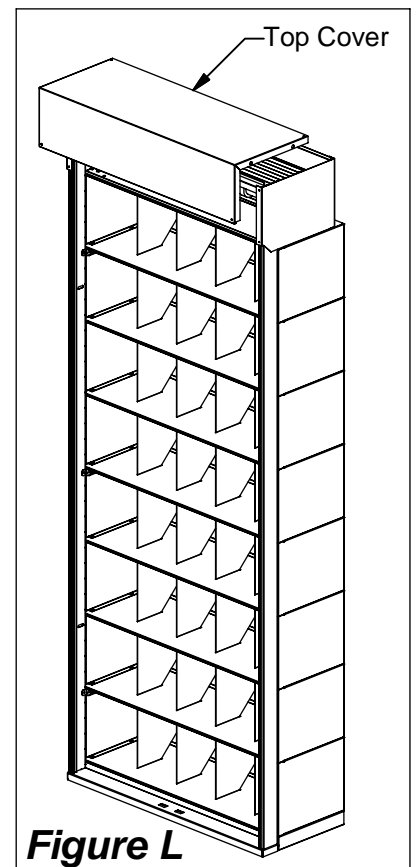

Vu-Stak Tambour Door Instructions

Step 11: Remove packaging materials in Tambour Box. Use four 1/4-20 x 1/2" Phillips Pan Head Machine Screws & Flanged Hex Nuts to secure the Tambour Box to the shelving. See **Figure M**.

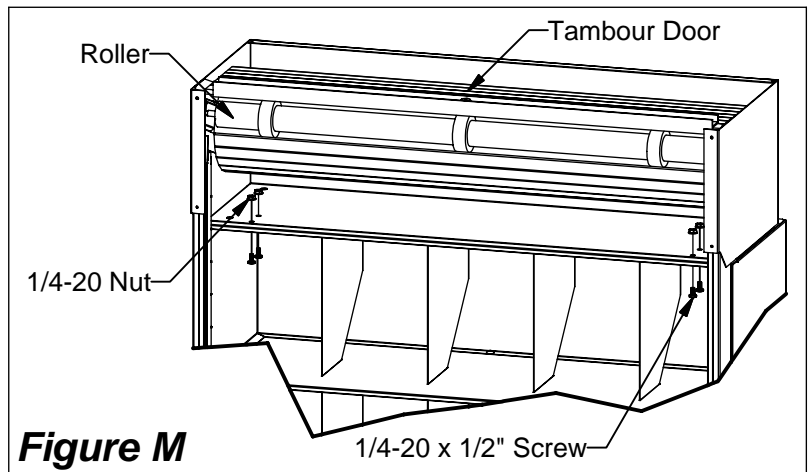
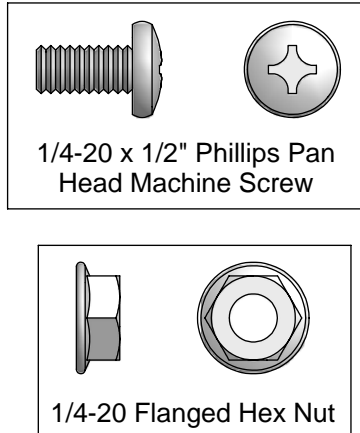
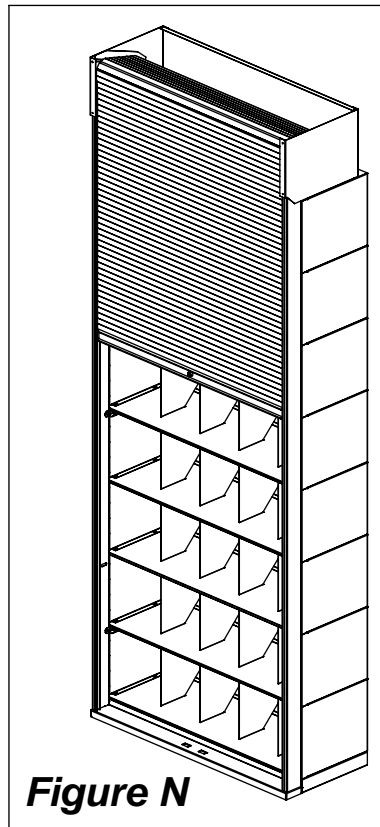
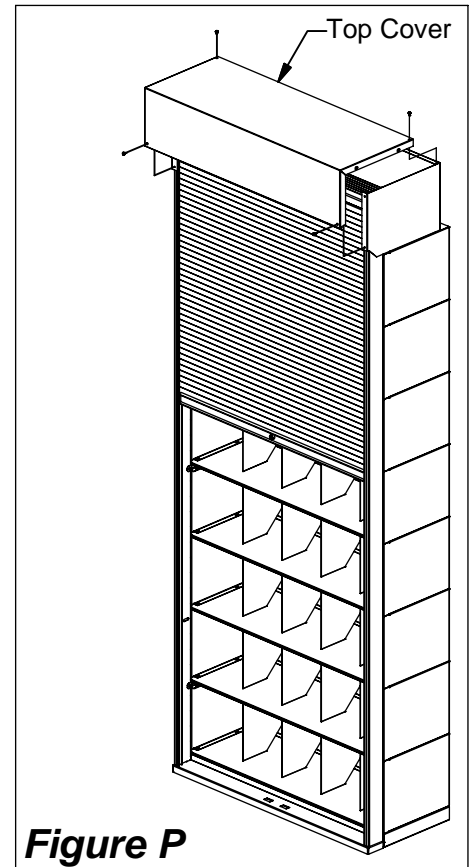

Figure M

Step 12: Align Tambour Door within Plastic Track of Uprights & pull door down. See **Figure N**. At this point, door should fully extend & retract smoothly. If door does not retract fully, refer to page 17 of Troubleshooting Section to verify door is being held in housing correctly.



Step 13: Check for smooth operation of door. Should door bind, jam or seems to be catching, refer to Troubleshooting Section on page 17.



Step 14: Install Top Cover with four #10 x 3/8" Phillips Pan Head Sheet Metal Screws. See **Figure P**.

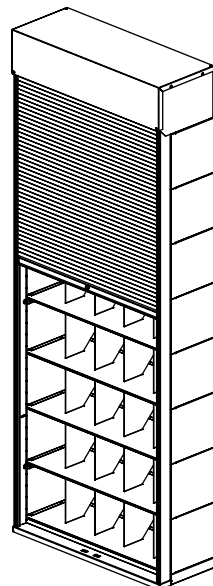

For assembly assistance, please call
1-866-217-0330.

4Post TambourDoor Instructions

Step 1: Four knockouts need to be removed from the top of the shelving. Use a hammer & screwdriver to aid in removal of knockouts. Knockouts are designated in **Figure A**.

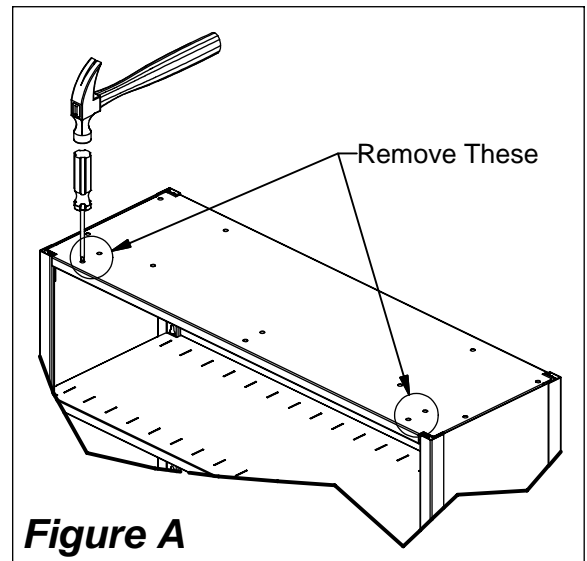

Figure A

Step 2: Position Door Frame Bottom in front of shelving as shown in **Figure B**.

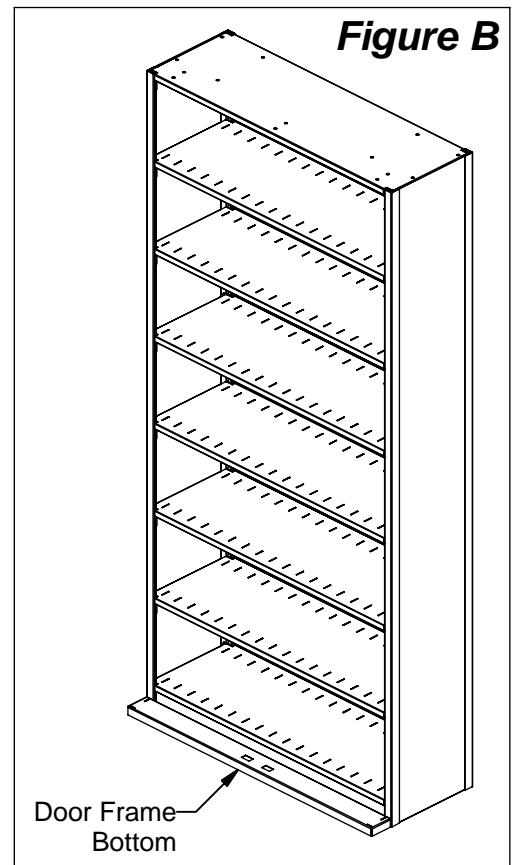
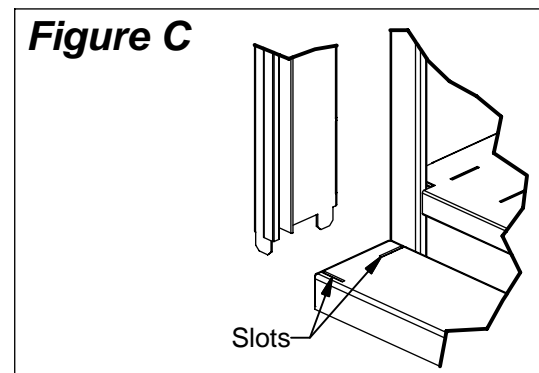
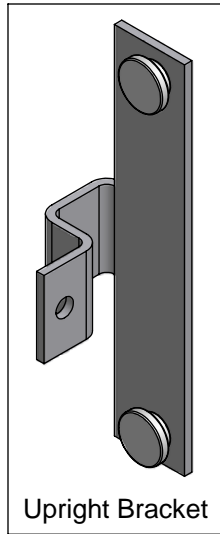

Figure C

Step 3: Position Left Upright as shown in **Figure C**. Tabs of Upright should fit into slots on Door Frame Bottom.



4Post TambourDoor Instructions



Step 4: Three Upright Brackets have to be installed for each Upright to secure it to shelving. Seat rivets of Bracket securely into keyholes on inside of shelving & fasten Bracket to Upright with a #8 x 3/8" Phillips Pan Head Tek Screw. See **Figure D** & **Detail E**.

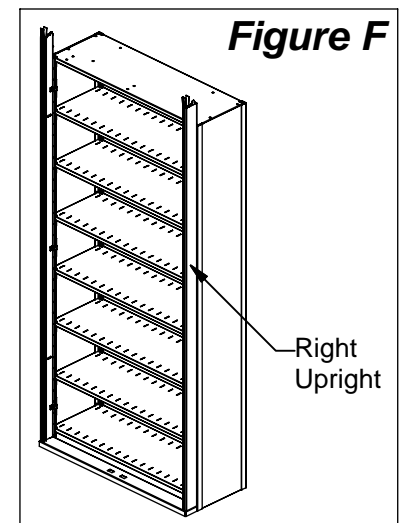
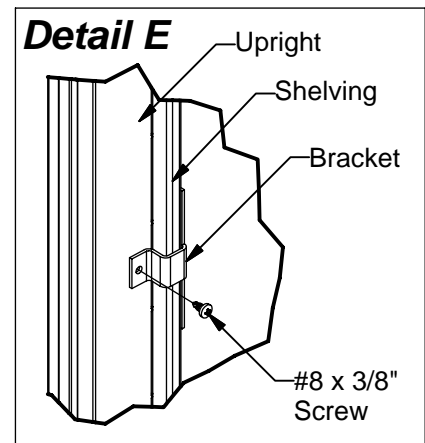
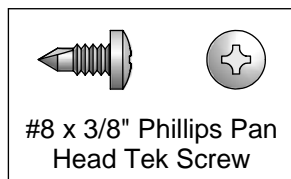
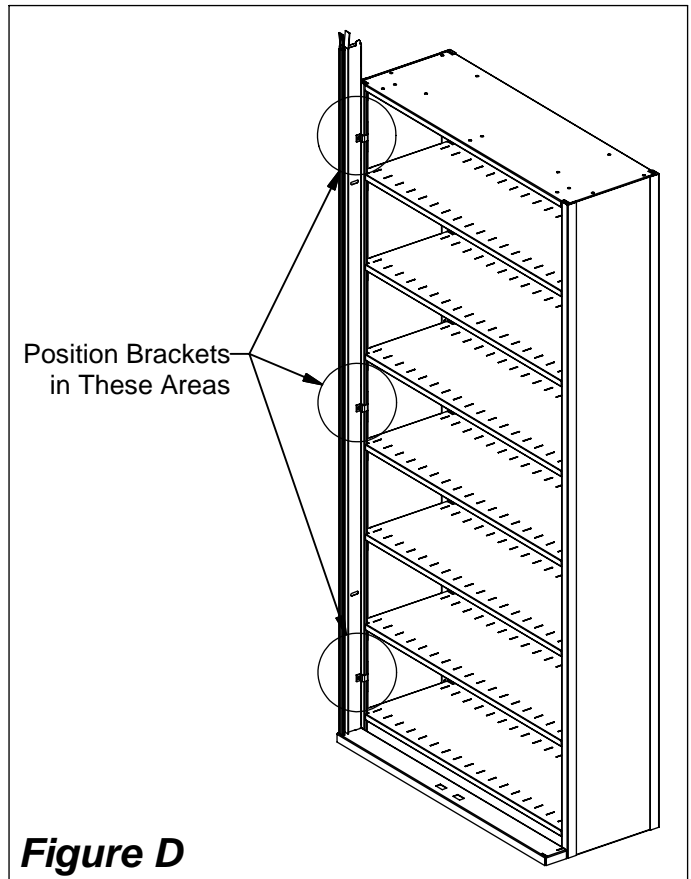

Step 5: Repeat **Steps 3 & 4** for Right Upright.

4Post TambourDoor Instructions

Step 6: Position Tambour Door Box on top of shelving & be certain that Uprights are aligned within openings in bottom of box. See **Figure G**.

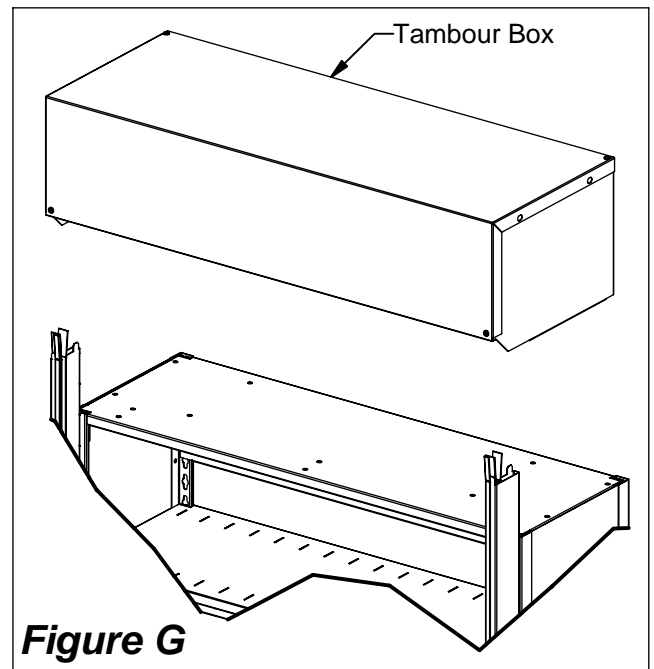

Step 7: Remove four #10 x 3/8" Phillips Pan Head Sheet Metal Screws from Tambour Door Box. See **Figure H**.

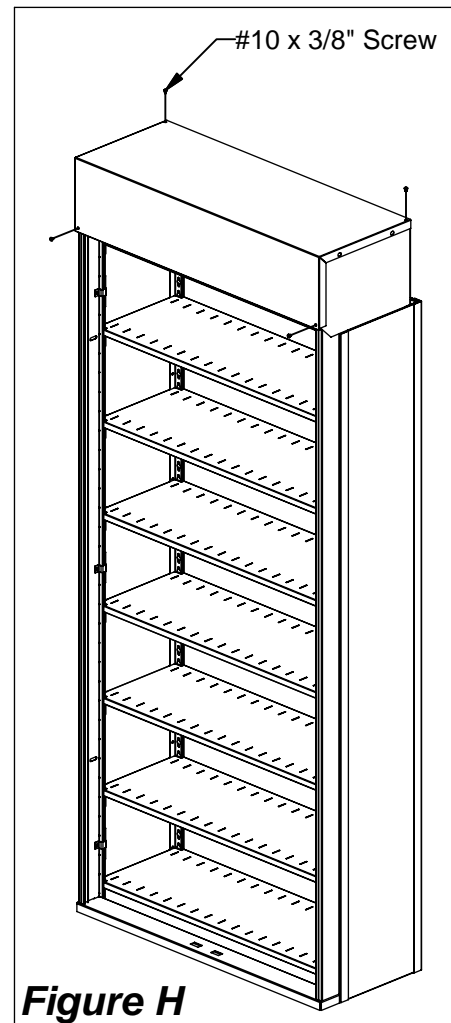
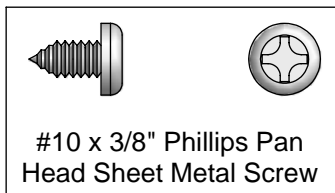

4Post TambourDoor Instructions

Step 8: Remove Top Cover from Tambour Door Box. See **Figure J**.

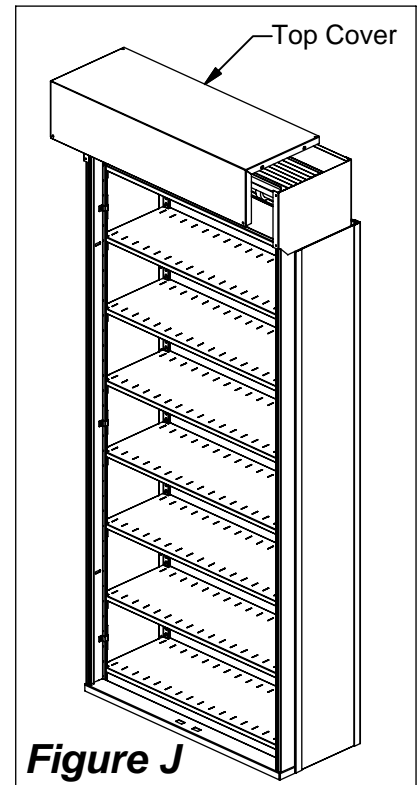

Step 9: Remove packaging materials in Tambour Box. Use four 1/4-20 x 1/2" Phillips Pan Head Machine Screws & Flanged Hex Nuts to secure the Tambour Box to the shelving. See **Figure K**.

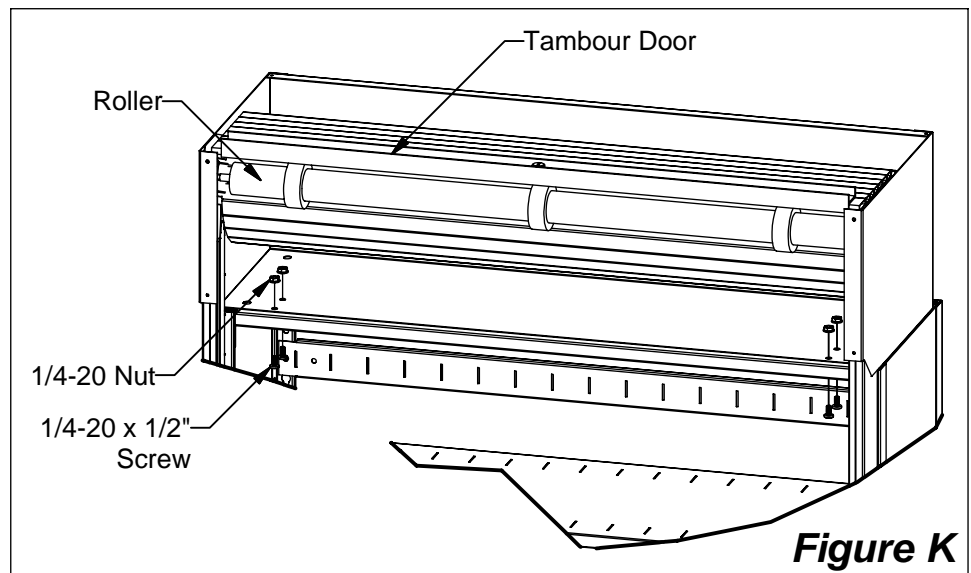
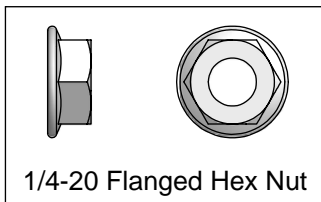
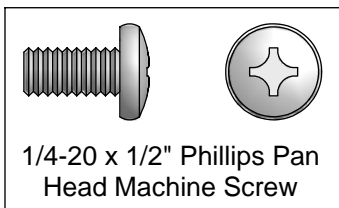

4Post TambourDoor Instructions

Step 10: Align Tambour Door within Plastic Track of Uprights & pull door down. See **Figure L**. At this point, door should fully extend & retract smoothly. If door does not retract fully, refer to page 17 of Troubleshooting Section to verify door is being held in housing correctly.

Step 11: Check for smooth operation of door. Should door bind, jam or seems to be catching, refer to Troubleshooting Section on page 17.

Step 12: Install Top Cover with four #10 x 3/8" Phillips Pan Head Sheet Metal Screws. See **Figure M**.

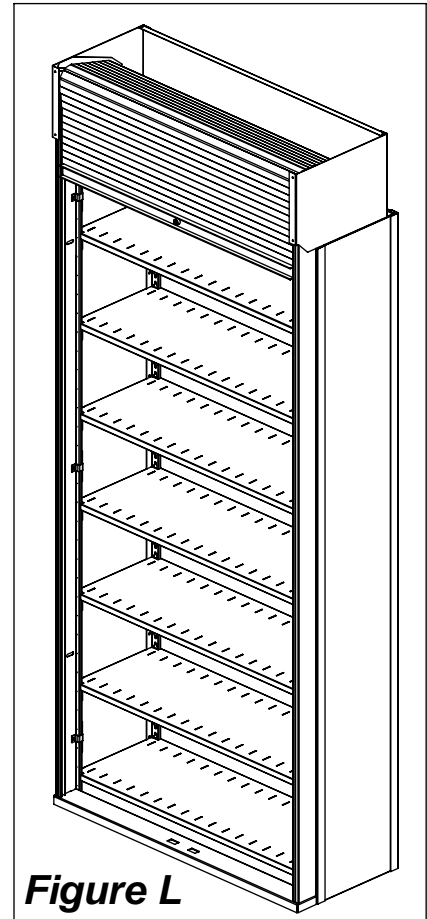
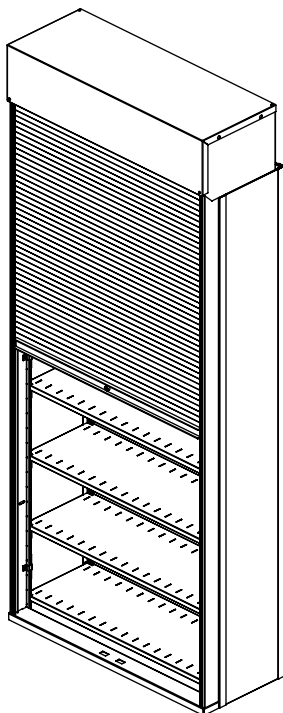

Figure L



For assembly assistance please call
1-866-217-0330.

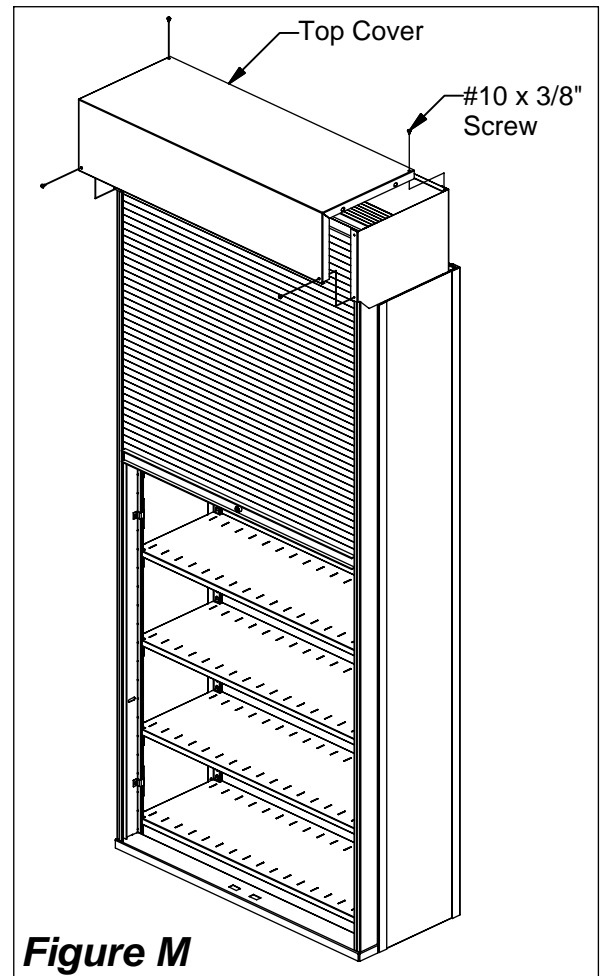

Figure M

TambourDoor Troubleshooting Section

Problem

Door will not close.

Solution

- Check to see that there is nothing blocking the door from closing. Look for items that are stored in cabinet that is interfering with door.
- Check to see that door is inside of plastic track on both uprights.

Problem

Door does not close smoothly or is catching while it's being closed.

Solution

- Make sure the plastic tracks are fully seated into uprights.
- Make sure that uprights are correctly attached to shelving. When installed correctly, the uprights will be butt-up against the inside of the tambour box with no gap.
- Make sure there's nothing stuck in the tracks.

Problem

Door will not move.

Solution

-Door may have become dislodged from the correct operating position within the box. If not already done so, remove the cover from the box. Verify that door is in fact dislodged. To do this, look into box & check to see if the gap between the door & the bottom of the box is equal on both sides. To reposition door in correct operating location, the door must first be removed from the housing. With door rolled up, be sure that the handle is positioned in the top to back position, then drop door into support channels on side of housing allowing each pin to be guided into slots.

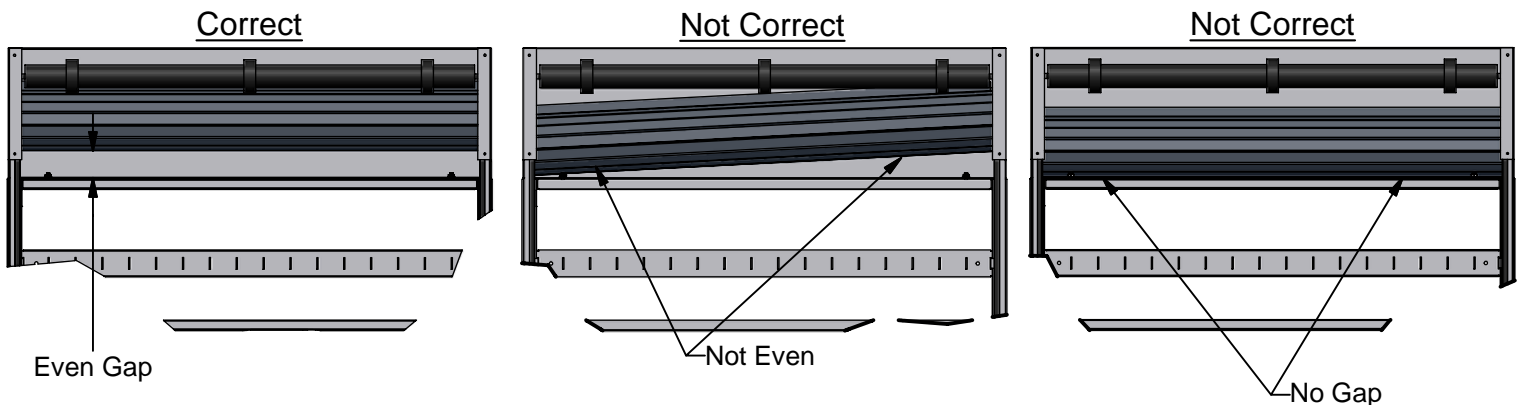

Tambour Door Troubleshooting Section

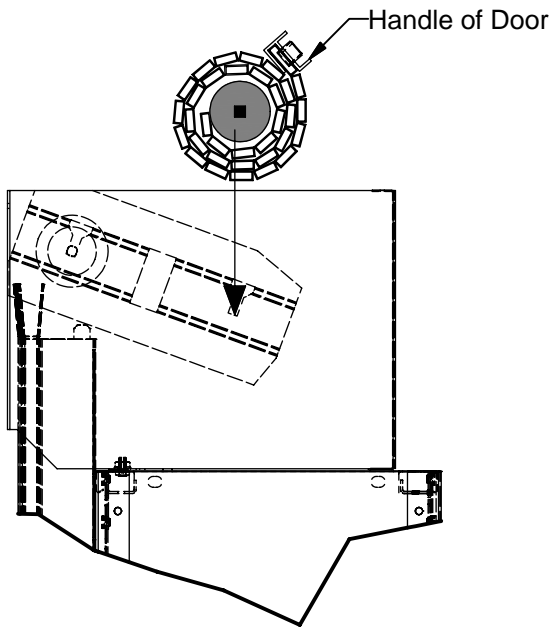

When reinstalling door, make sure handle is positioned towards rear of cabinet as shown.

Door must be installed one side at a time. Seat square pin of door in slot of support channel. Then position other pin in opposite side.

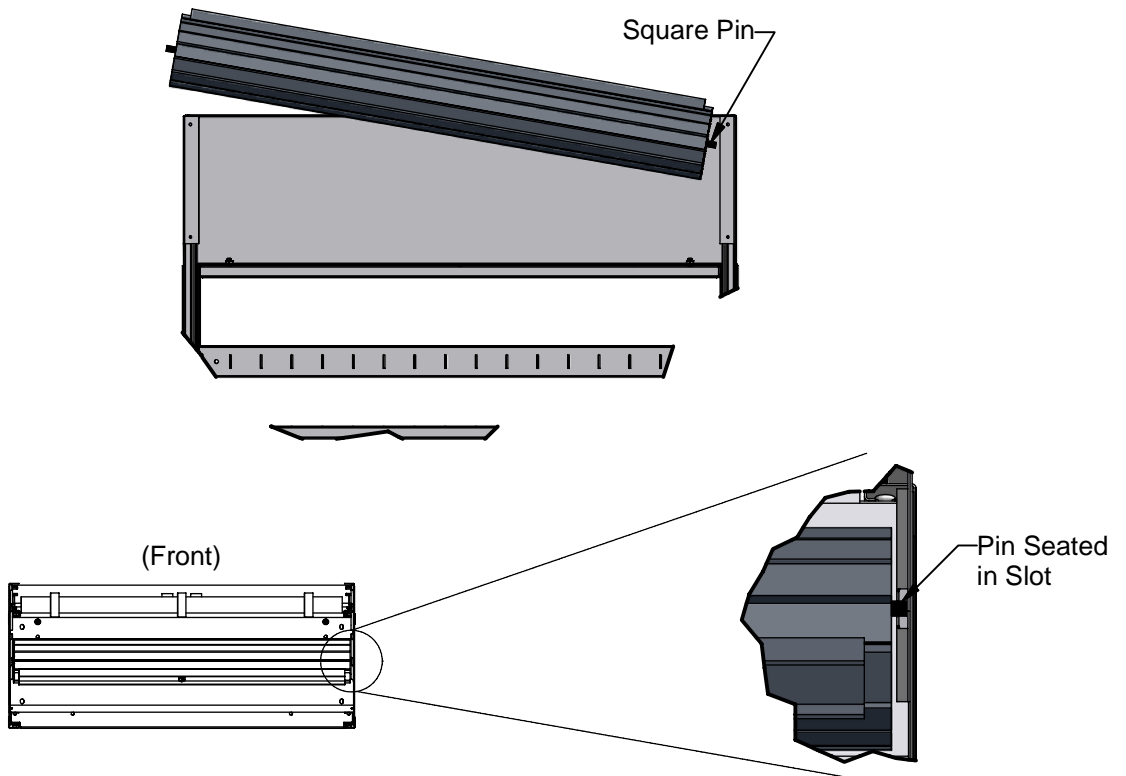

For assembly assistance please call
1-866-217-0330.

TambourDoor Operating Instructions

Normal Operating Instructions

When opening & closing the door, it is important to keep the movement of the door under control at all times.

Use the handle and finger grip to move the door.

When opening the door, do not let the door retract into the upper housing uncontrolled.

When closing the door, keep movement to a reasonable speed.

When locking door, do not push or pull on handle while turning the key, this will help ensure that lock functions correctly.

Do's & Don'ts of Tambour Door Operation

Do control the speed of the door while operating.

Do keep the track clear of debris.

Don't slam the door closed.

Don't let the door retract into housing uncontrolled.

Don't use your foot to close the door.

WARNING

*Failure to operate the tambour door
correctly will void the warranty.*

For assembly assistance please call
1-866-217-0330.