

Stak N Lok™
assembly instructions for 2 piece units
*****IMPORTANT*** Please read**
entire assembly sheet before
assembly

Tools required: Allen key (provided), Hammer

- 1.) 7 HIGH Stak N Lok™ units will now be shipped in two pieces to reduce the chance of damage during shipping.
- 2.) Remove packaging materials from bottom half of Stak N Lok™ unit. Place bottom half of unit in the desired location.
- 3.) Remove packaging materials from top half of unit. Carefully place top half of unit on bottom half of unit making sure that the clips on the top half slide over the flange on the bottom half. You may want to have someone help with lifting since unit is bulky.
- 4.) Connect lock bars together using screws and Allen key (2 sides). **DO NOT** over tighten.
- 5.) Finally, place 4 drive rivets into holes on inside of unit (2 in front holes and 2 in rear holes). Using a hammer, drive rivet pins into the body of the rivets until pins are flush with the top of the rivet head.

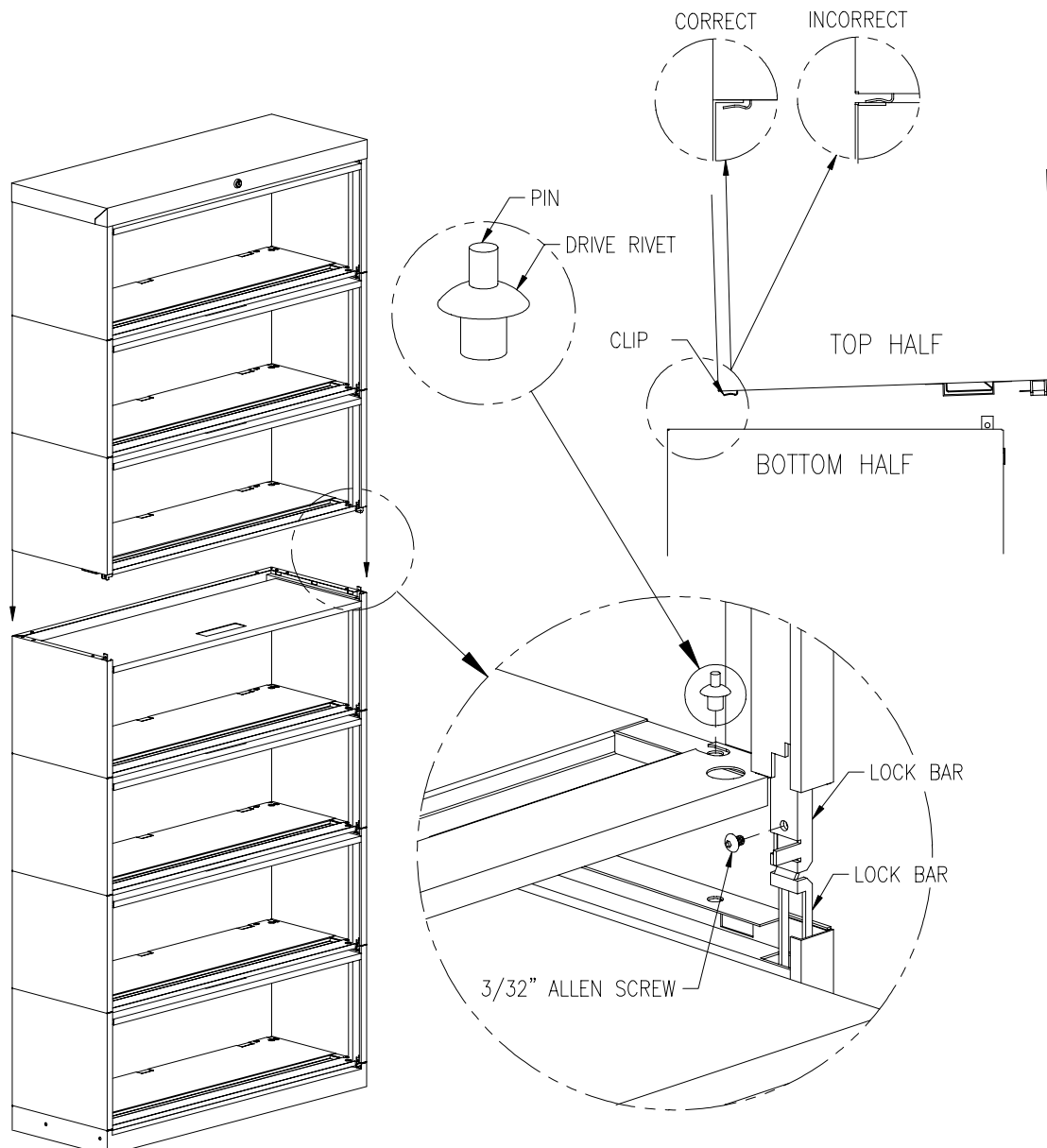

Stak N Lok™

assembly instructions for 2 piece units with posting shelf

*****IMPORTANT***** Please read

entire assembly sheet before
assembly

Tools required: Allen key (provided), Hammer

- 1.) 7 HIGH Stak N Lok™ units will now be shipped in two pieces to reduce the chance of damage during shipping.
- 2.) Remove packaging materials from bottom half of Stak N Lok™ unit. Place bottom half of unit in the desired location.
- 3.) Remove packaging materials from top half of unit. Carefully place top half of unit on bottom half of unit making sure that the clips on the top half slide over the flange on the bottom half. You may want to have someone help with lifting since unit is bulky.
- 4.) Connect lock bars together using screws and Allen key (2 sides). **DO NOT** over tighten.
- 5.) Finally, place 4 drive rivets into holes on inside of unit (2 in front holes and 2 in rear holes). Using a hammer, drive rivet pins into the body of the rivets until pins are flush with the top of the rivet head.

