

Rigid Rak 800 Series Free Standing Rack Assembly Instructions

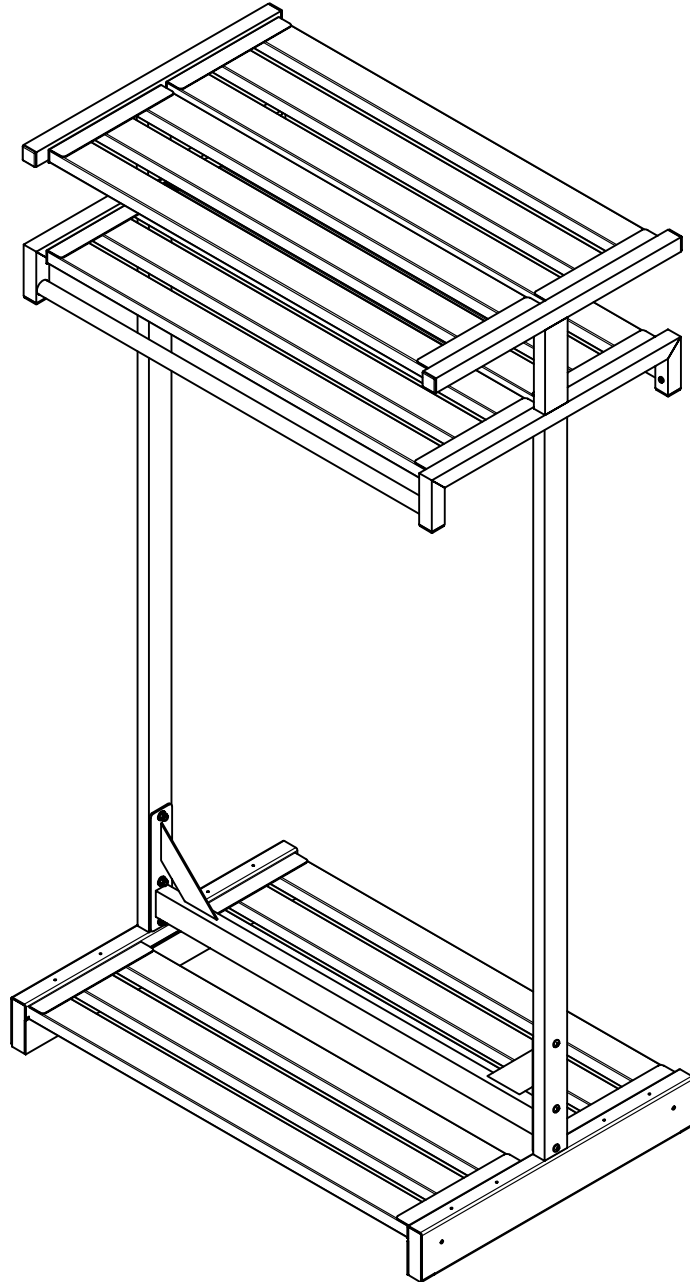

814 Series Shown
w/ Optional BootShelf

Table of Contents:

Table of contents.....	1
Required Tools, Included Hardware.....	2
Footing, Upright, & Crossmember assembly.....	3
Overhead Shelving Assembly.....	4
Shelving to Rack assembly.....	5
Optional Components assembly.....	5-6
Safety Precautions & Customer Service Contact.....	6

Required Tools

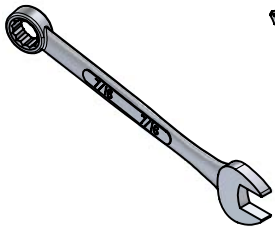

7/16" Wrench

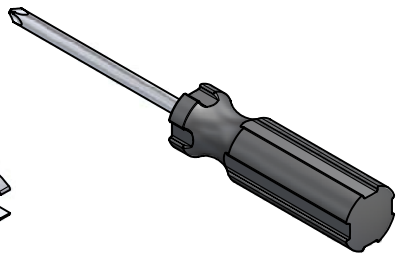

Phillips Screwdriver

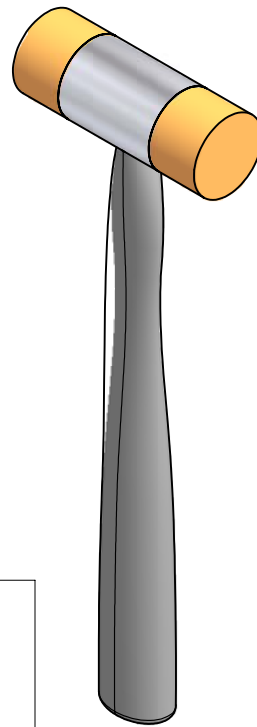

Plastic Tip Hammer



or Rubber Mallet

Included Hardware

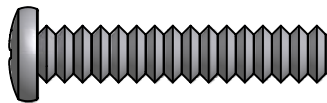

1/4-20 x 1-1/2" Phillips Panhead

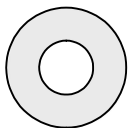

1/4" Flat Washer



1/4-20 Nylock Nut



#10-24 x 1/2" Phillips Panhead

NOTE:

All Free Standing Rack Units are assembled the same with the only differences being the footings and shelf brackets on the single faced and double faced units. Any rack length over 5' consists of (1) starter rack and (1) or more add on racks.

Figure A

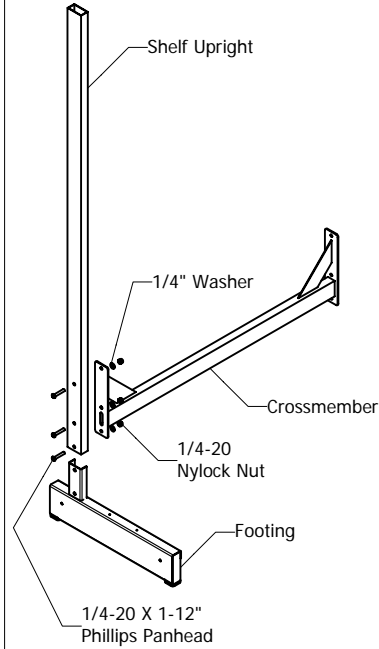

STEP 1:

Slide the shelf upright over the U-channel on the footing. Push the shelf upright down into position aligning the holes in the U-channel with the holes in the shelf upright.

STEP 2:

Position the crossmember against the shelf upright and bolt together using (3) 1/4-20 x 1-1/2" phillips panhead screws, (3) 1/4" flat washers, and (3) 1/4-20 nylock nuts, as shown in Figure A. Do not completely tighten hardware at this time.

NOTE:

If you are adding an add on rack at this time, swap the middle footing from the add on rack for the left or right footing with the base rack, depending on what side you are adding the rack to.

STEP 3:

Repeat steps 1 & 2 to attach the other upright and footing for the assembly, as shown in Figure B. Tighten the hardware at this time. Set the assembly to the side for now. It is not needed until the top shelf is assembled.

Figure B

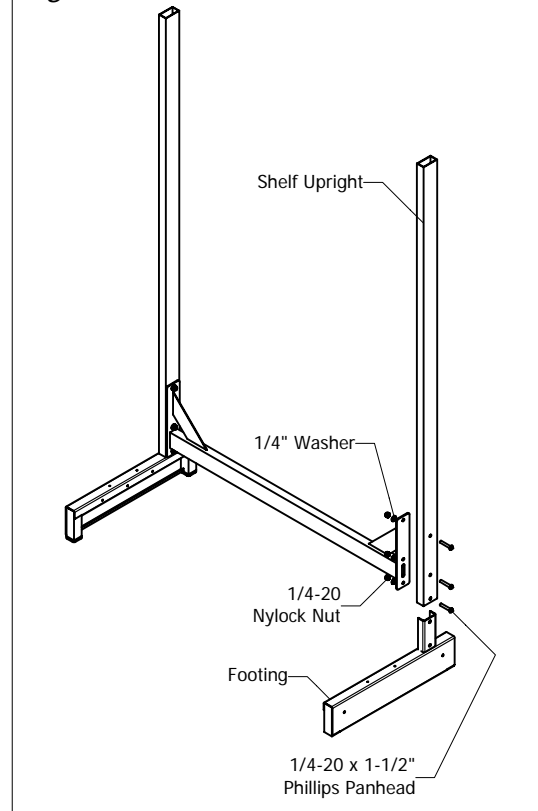
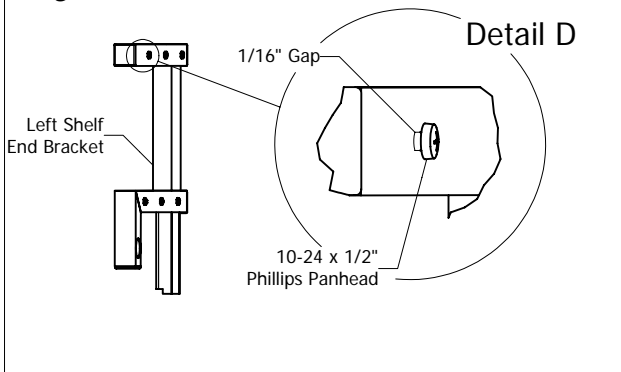

Figure C



STEP 4:

Run (3) #10-24 x 1/2" phillips panhead screws in each shelf end bracket, for each shelf used, leaving at least a 1/16" gap between the head of the screw and the side of the shelf end bracket. See Figure C & Detail D.

Figure E

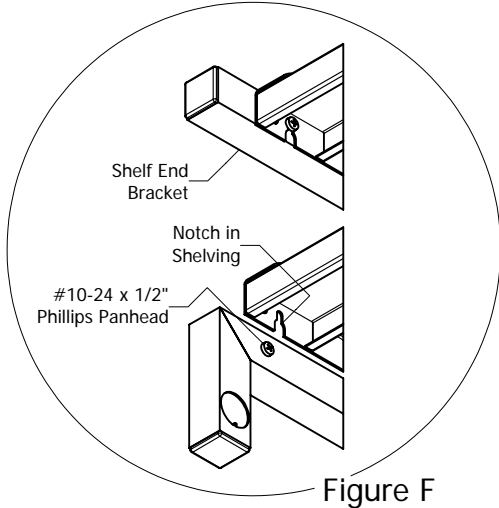
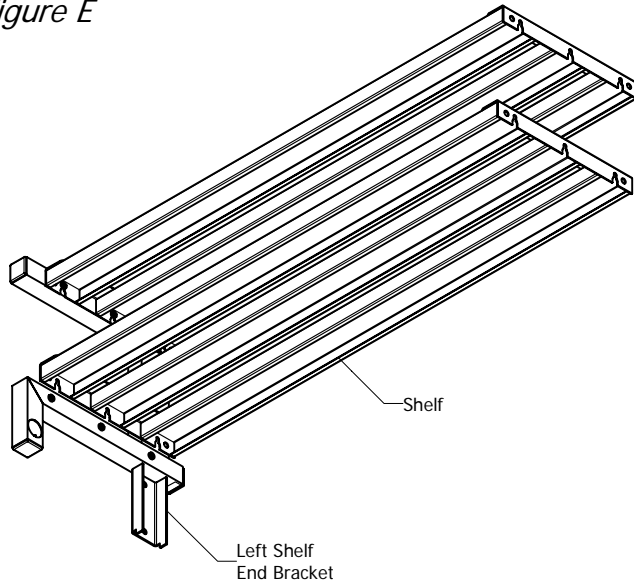
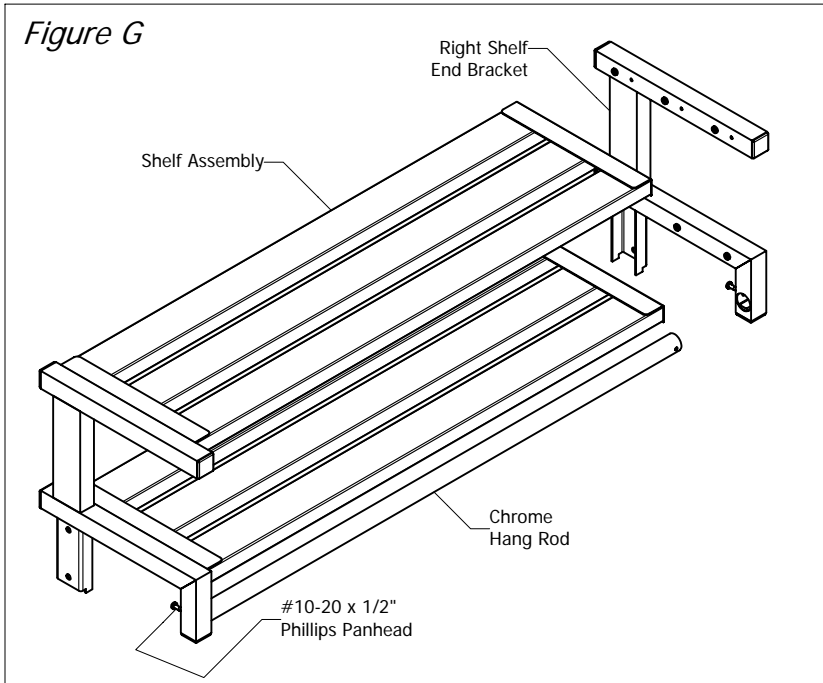

Figure F

STEP 5:

Position the shelf end bracket over the screws. Push the shelf down over the screws, seating the small part of the notch in the shelving on top of the screws as shown in Figure F. Tighten screws at this point.

Figure G



STEP 6:

Insert chrome hang rod into the hole in the side of the left shelf bracket. Secure with (1) #10-20 x 1/2" phillips panhead in the left shelf end bracket.

NOTE:

If you are adding an add on rack at this time, swap the middle shelf end bracket from the add on rack for the left or right shelf end bracket with the base rack, depending on what side of the rack you are adding to.

STEP 7:

Attach the right shelf end bracket to the assembly in the same manner as the left side, making sure the shelves are seated all the way before the screws are tightened. Use (1) #10-24 x 1/2" phillips panhead screw to secure the hangrod on the right shelf end bracket also.

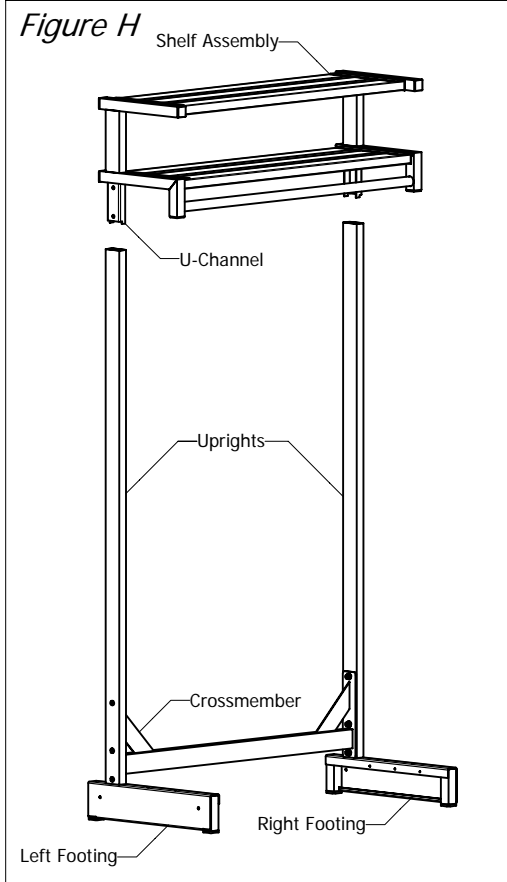

STEP 8:

Insert U-Channel into top of uprights and push down. It may be necessary to tap on the shelf assembly with a **rubber mallet**, (do not use a regular hammer as this will mar the finish on the assembly), to seat the shelf assembly against the uprights.

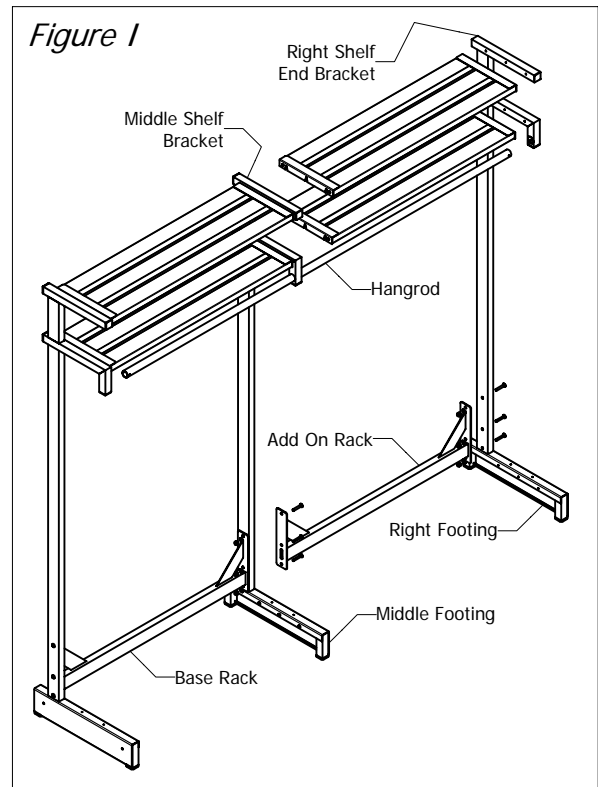

Assembly Of Optional Components

Add On Kits

Double faced add on models can be added to the left or right side of the free standing unit. Single faced add on models must be ordered left or right. Both come in various lengths. Depending on the total length of your unit a Splice Kit may be necessary for assembly of the hangrod. (See Figure J.)

Step 9:

Swap the middle footing from the add on rack with the footing from the base rack. Do not replace the hardware yet.

Step 10:

Assemble the footing from the base rack with the upright and crossmember for the add on rack but do not tighten hardware at this time.

Step 11:

Loosen all screws on the shelving on the side of your existing unit where you are going to attach your add on unit.

Step 12:

Install (3) #10-24 x 1/2" screws in all holes on the middle shelf end bracket for each shelf used, leaving at least a 1/16" gap as shown in Detail D, and swap the middle shelf end bracket with the one on the base rack.

Step 13:

Install hangrod through the middle shelf end bracket and seat in the shelf end bracket. Then insert the u-channel from the shelf end bracket into the upright. There should be enough play in the parts to insert the hangrod into the last shelf end bracket. Install screws to hold hangrod in place.

Step 14:

Install shelving on the top of the add on rack and tighten screws at this time. Tighten all other hardware at this time also.

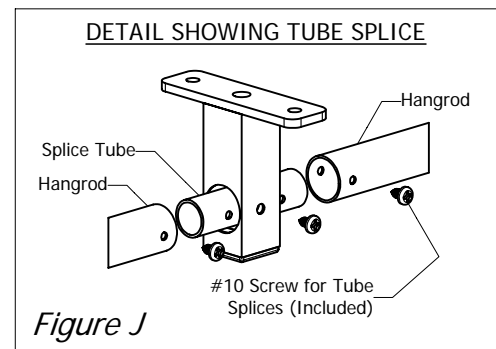
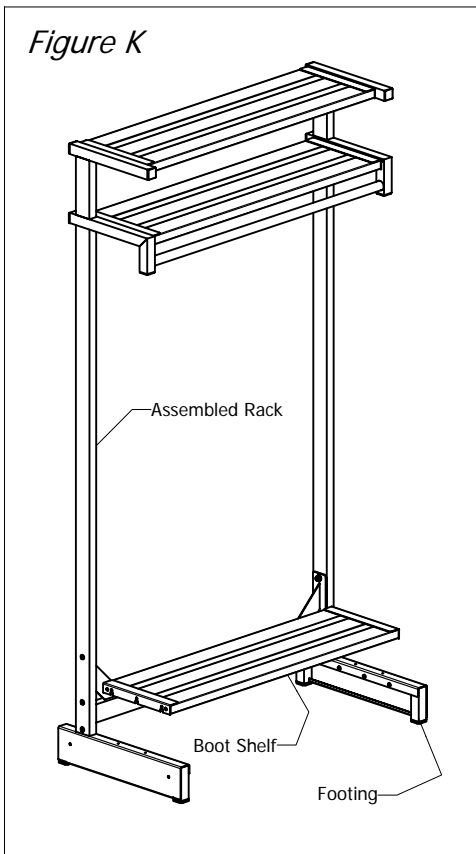

Figure K



Boot Shelf

Step 15:

Install (3) #10-24 x 1/2" phillips panhead screws in each footing for every boot shelf being added to your rack leaving at least a 1/16" gap between the head of the screw and the footing. Drop the boot shelf over the heads of the screws and push down to seat the shelf. Tighten the screws. See Figure K and Detail L.

Detail L

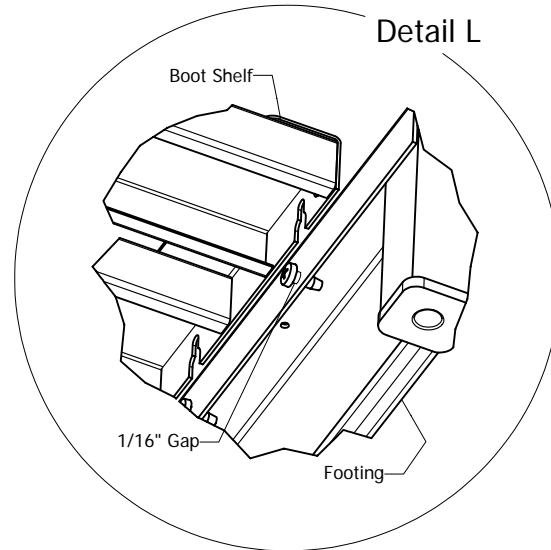

Casters

Step 16:

Lay rack assembly on its back on the floor and insert the stem of the caster into the hole on the plastic footing insert. Tap on the caster with a plastic tip hammer to seat the caster in the plastic insert. Repeat for all the remaining casters for the rack. See Figure M.

SAFETY PRECAUTIONS:

- 1) Read through these instructions again insuring that all steps were completed.
- 2) Recheck & tighten any loose bolts or fittings.

FOR ASSEMBLY ASSISTANCE CONTACT CUSTOMER SERVICE AT 1-866-217-0330 (MONDAY THRU FRIDAY 8AM-5PM EST)

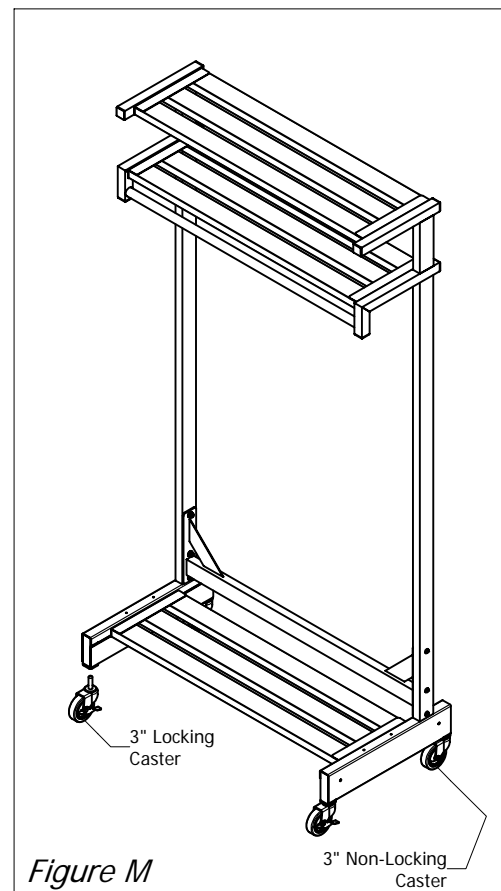

Figure M