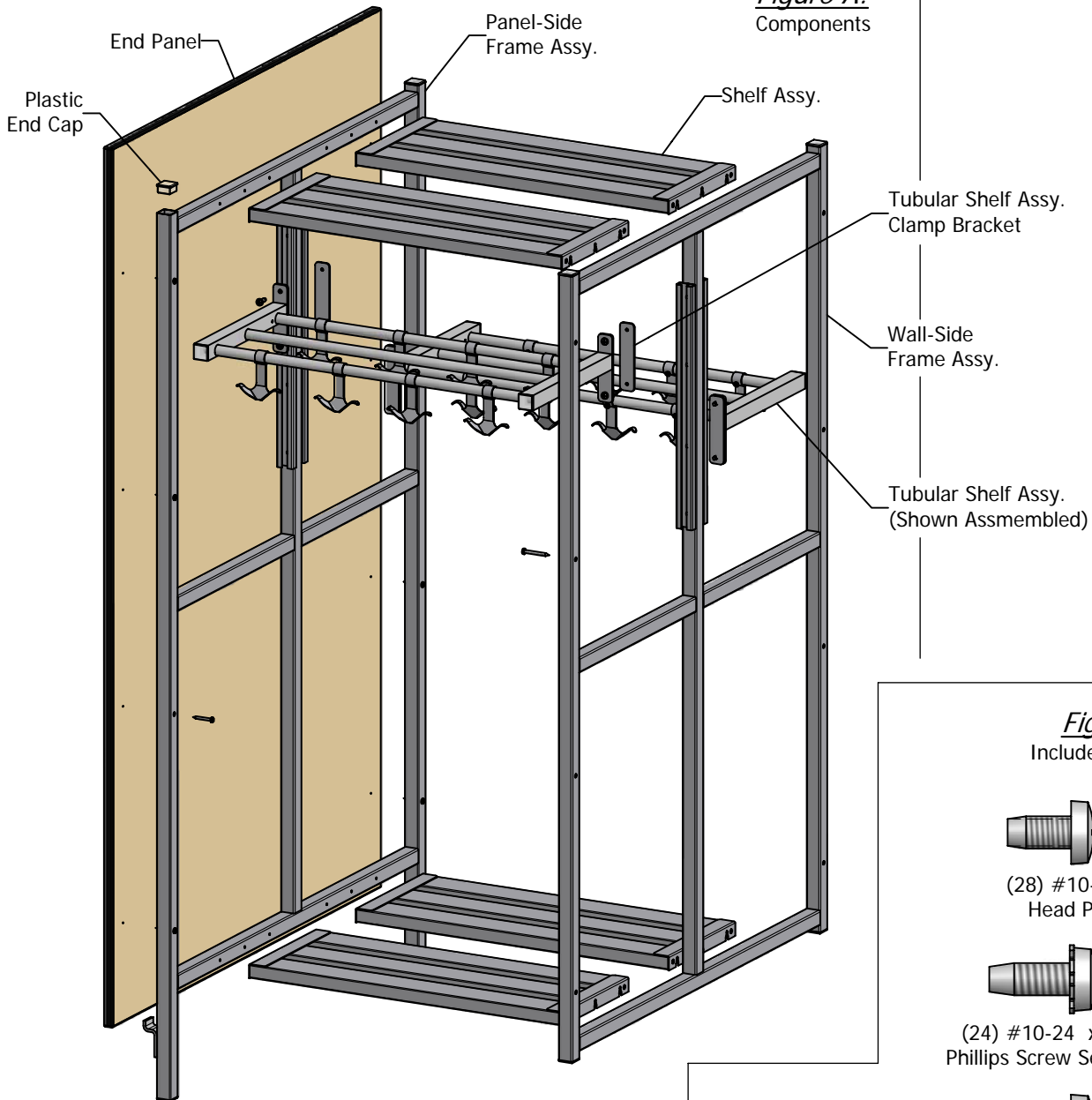

TABLE OF CONTENTS:	
TABLE OF CONTENTS	1
HARDWARE & ASSEMBLY TOOLS	2
ASSEMBLY INSTRUCTIONS	3-6

FOR ASSEMBLY ASSISTANCE CONTACT  
CUSTOMER SERVICE AT 1-866-217-0330  
(MONDAY THRU FRIDAY 8AM-5PM EST)

TITLE		670LP WARDROBE ASSEMBLY	
SHEET	DWG NO	REV	
1 OF 6	INST0125	1	

**Figure A:**  
Components



**Figure B:**  
Included Hardware



(28) #10-32 x 3/8" Pan Head Phillips Screw

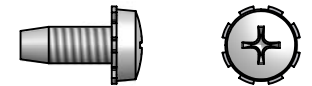

(24) #10-24 x 1/2" Pan Head Phillips Screw Self-Tap w/Washer

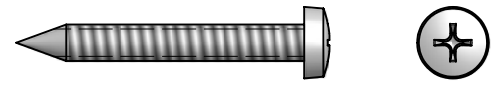

(8) #10 x 1-1/2" Pan Head Phillips Screw



(8) #12 x 2" Pan Head Phillips Screw

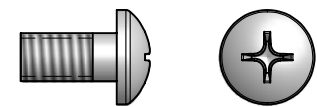

(8) 1/4-20 x 1/2" Pan Head Phillips Screw

FOR ASSEMBLY ASSISTANCE CONTACT  
CUSTOMER SERVICE AT 1-866-217-0330  
(MONDAY THRU FRIDAY 8AM-5PM EST)

TITLE **670LP WARDROBE ASSEMBLY**

SHEET 2 OF 6

DWG NO

**INST0125**

REV 1

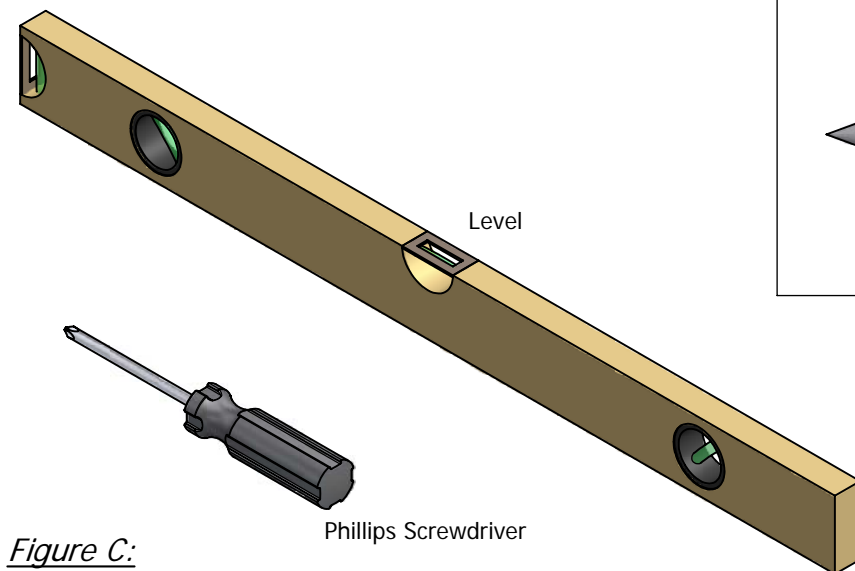

**Figure C:**  
Required Tools

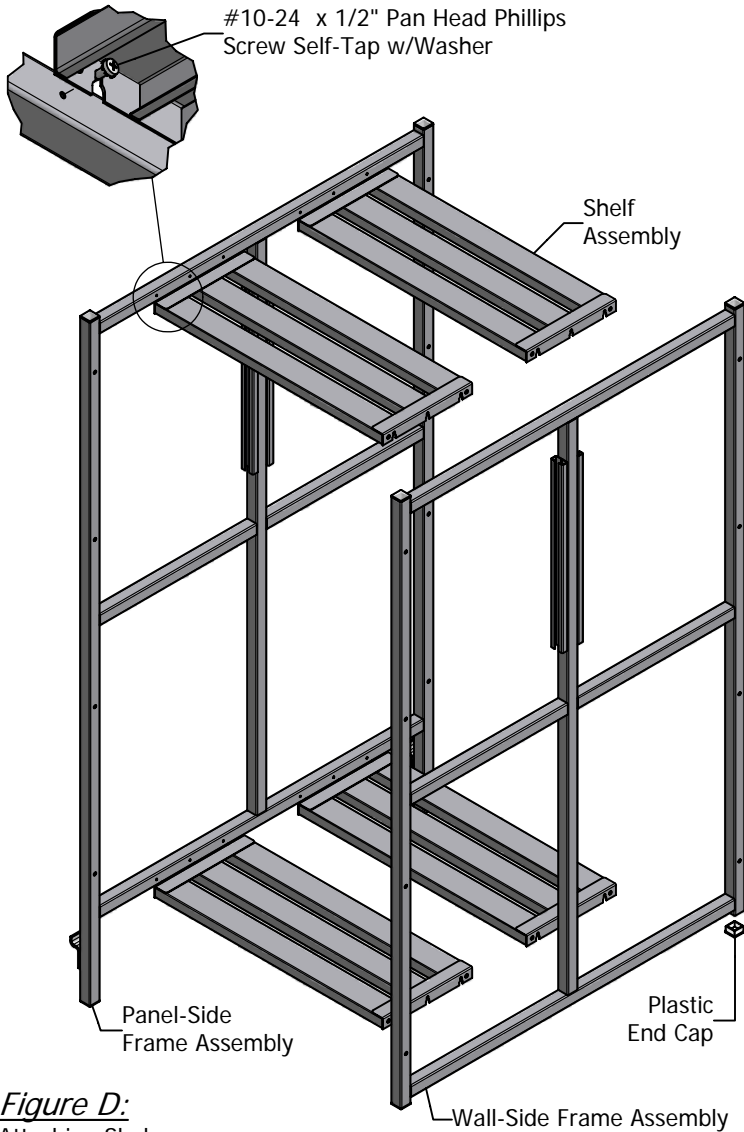

**Figure D:**  
Attaching Shelves

### **STEP 1: Preparing to Install**

Open all boxes, make sure that all components for your order have been received and that all required tools are available. Read all instructions completely before proceeding to Step 2.

### **STEP 2: Attaching Shelves**

Locate the (4) Shelf Assemblies and the (2) Frame Assemblies. Note the difference in leg length (Figure D) at the bottom of the frame assemblies; the wall-side assembly has the shorter legs. Attach the shelves to the frames with (6) #10-24 screws per shelf as shown in Figure D. Insert a plastic end cap into the top & bottom of each of the frame assembly legs (8 total).

FOR ASSEMBLY ASSISTANCE CONTACT  
CUSTOMER SERVICE AT 1-866-217-0330  
(MONDAY THRU FRIDAY 8AM-5PM EST)

TITLE			670LP WARDROBE ASSEMBLY	
SHEET	DWG NO	REV		
3 OF 6	INST0125	1		

**Figure E:**  
Attaching to Wall

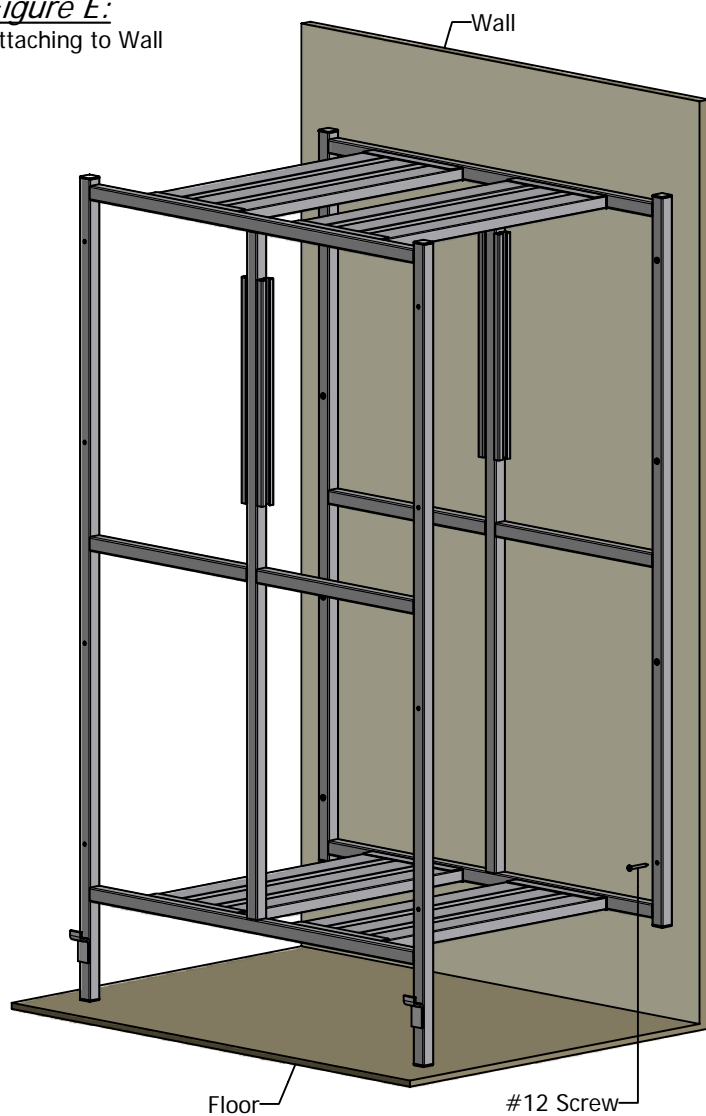

### **STEP 3: Attaching to Wall**

With shelves in place, place the unit in the selected location against the wall. Once the unit has been leveled, use the included #12 x 2" screws to secure the unit to the wall through the (4) holes in each of the outer uprights on the wall-side frame assembly (Figure E).

FOR ASSEMBLY ASSISTANCE CONTACT  
CUSTOMER SERVICE AT 1-866-217-0330  
(MONDAY THRU FRIDAY 8AM-5PM EST)

TITLE			670LP WARDROBE ASSEMBLY		
SHEET	DWG NO			REV	
4 OF 6	INST0125			1	

**Figure F:**  
Attaching 200 Series  
Tubular Shelves

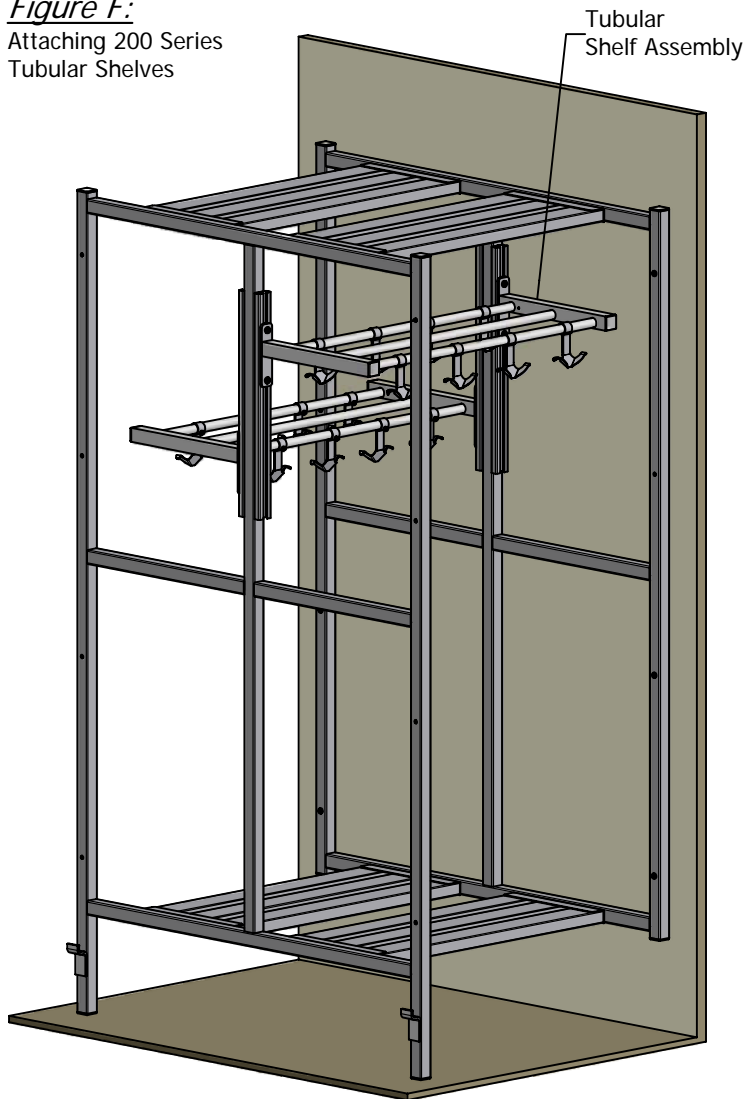

**STEP 4: Attaching Tubular Shelves**

See separate instructions for assembly of 200 series tubular shelf systems. Once assembled and attached; your unit should look similar to Figure F.

FOR ASSEMBLY ASSISTANCE CONTACT CUSTOMER SERVICE AT 1-866-217-0330 (MONDAY THRU FRIDAY 8AM-5PM EST)		
TITLE	670LP WARDROBE ASSEMBLY	
SHEET	DWG NO	REV
5 OF 6	INST0125	1

**Figure F:**  
Attaching Outer Panel

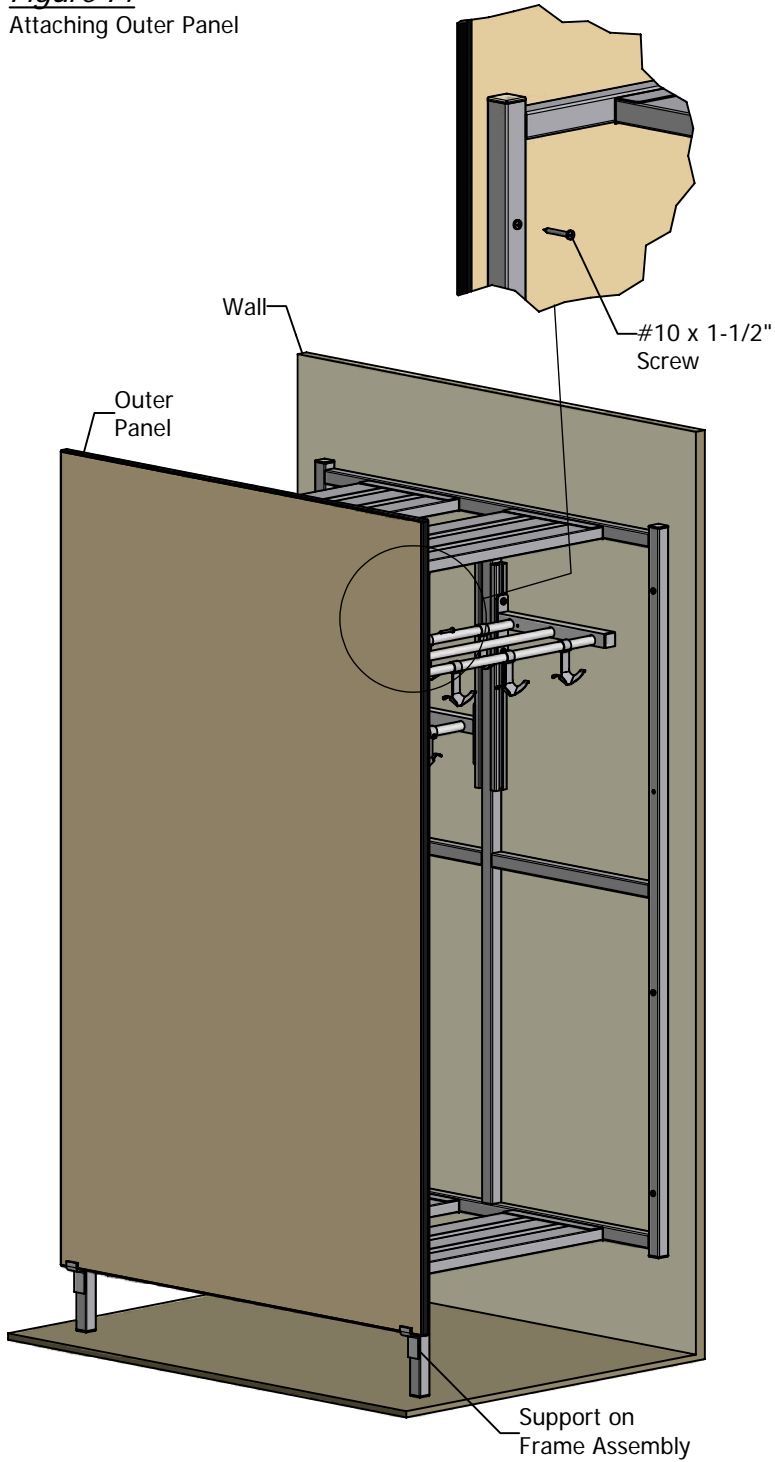

**STEP 5: Attaching Outer Panel**

Place outer panel onto supports on frame assembly and center panel from left-right. Use the included #10 screws to secure the panel to the frame. Your wardrobe unit is now ready for use.

**END OF INSTRUCTIONS**

FOR ASSEMBLY ASSISTANCE CONTACT  
CUSTOMER SERVICE AT 1-866-217-0330  
(MONDAY THRU FRIDAY 8AM-5PM EST)

TITLE			670LP WARDROBE ASSEMBLY	
SHEET	DWG NO	REV		
6 OF 6	INST0125	1		