

Dump Rim Installation Instructions

Figure A

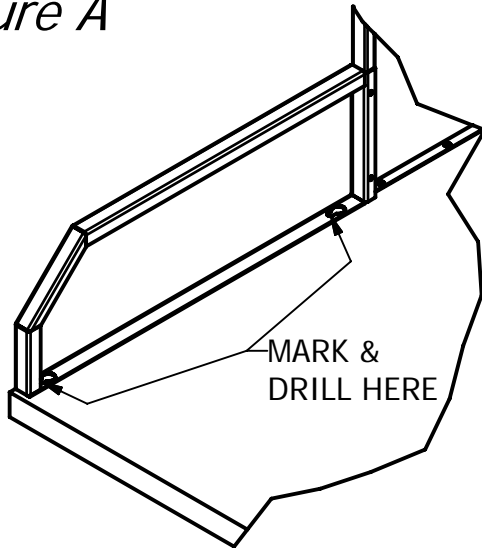

Step 1: Place rim flush against riser. Mark a hole in each keyhole, centering it in the smaller of the circles.

Step 2: Remove rim and drill one 1/16" hole at each mark about 1/4" deep.

Figure B

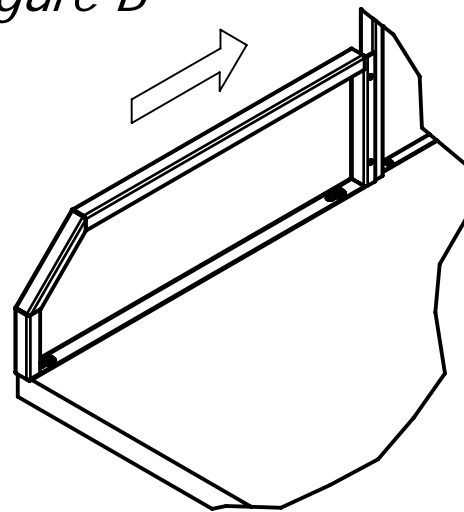

Step 3: Install #10 x 1/2" wood screws. Do not fully tighten. Instead leave enough room to fit the dump rim underneath the screws.

Step 4: Place rim over screws and slide rim flush against riser. Finish tightening screws. See Figure B.

Figure C

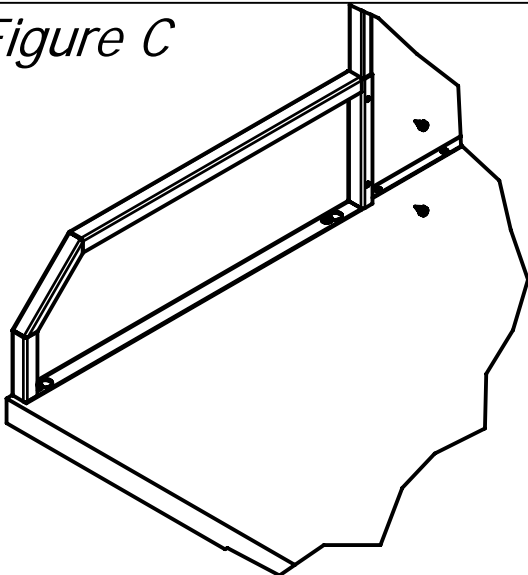

Step 5: Using a drill gun and phillips screw tip, screw #8 x 3/8" pan head tek screws through holes in dump rim into riser panel.

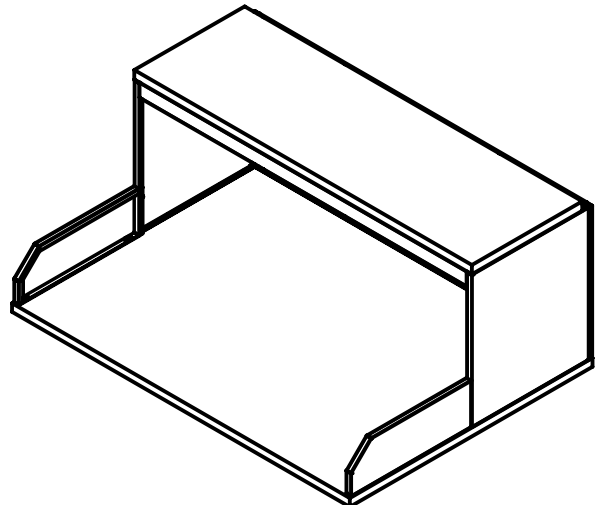

If you need assembly assistance, please contact Customer Service at 1-866-217-0330 (Monday through Friday 8:00 AM - 5:00 PM E.S.T.)