

RWT RISER INSTALLATION INSTRUCTIONS

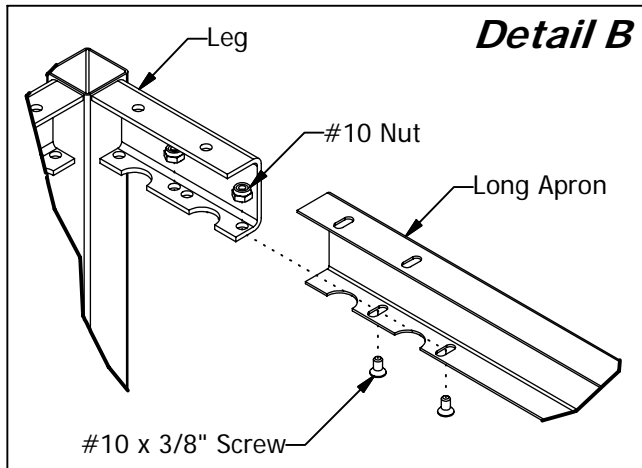

Step 1: Assemble Legs to Aprons using a total of sixteen #10-24 x 3/8" Phillips Flat Head Machine Screws & Nylock Nuts. See *Figure A* & *Detail B*.

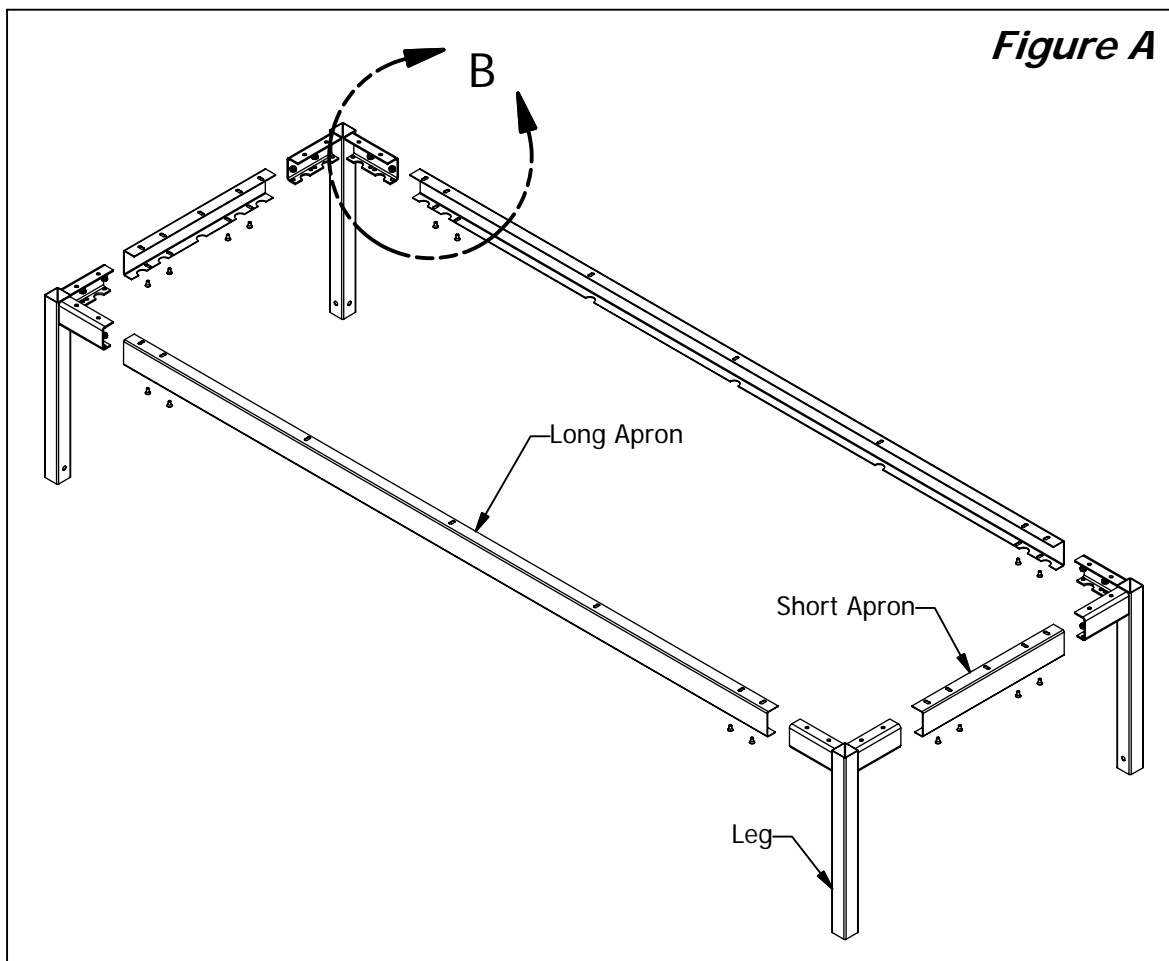

RWT RISER INSTALLATION INSTRUCTIONS

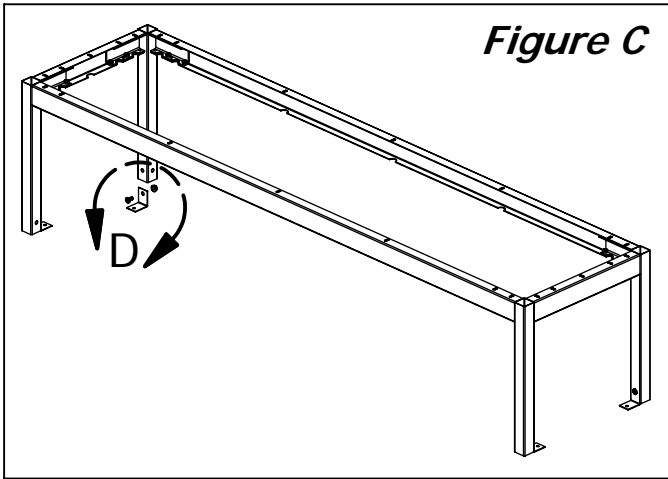

Step 2: Fasten an Anchor Bracket to each Leg with a 1/4-20 x 1/2" Phillips Pan Head Machine Screw & Flanged Hex Nut. See *Figure C* & *Detail D*.

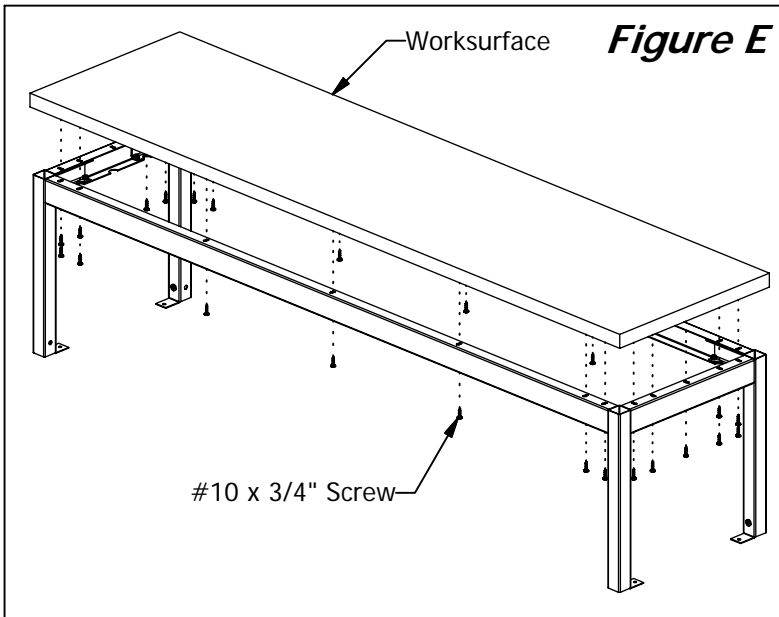
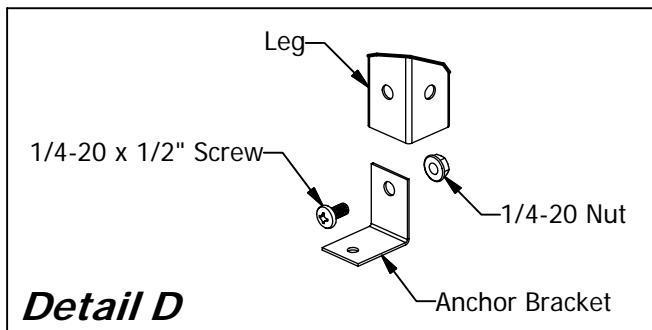

Step 3: OPTIONAL WORKSURFACE
Fasten Worksurface to Riser using #10 x 3/4" Wood Screws. See *Figure E*.

RWT RISER INSTALLATION INSTRUCTIONS

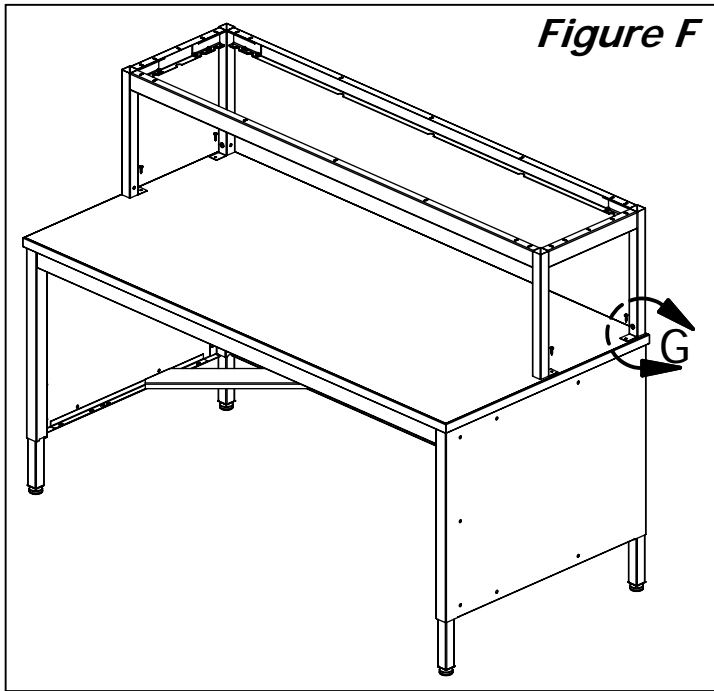

Step 4: Secure Riser to Table with four #10 x 3/4" Wood Screws as shown in *Figure F* & *Detail G*.

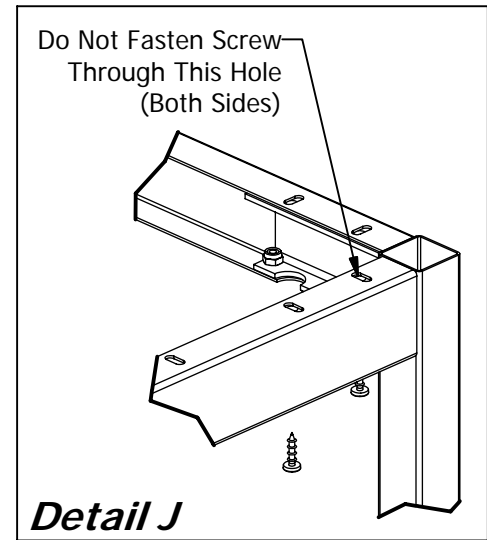
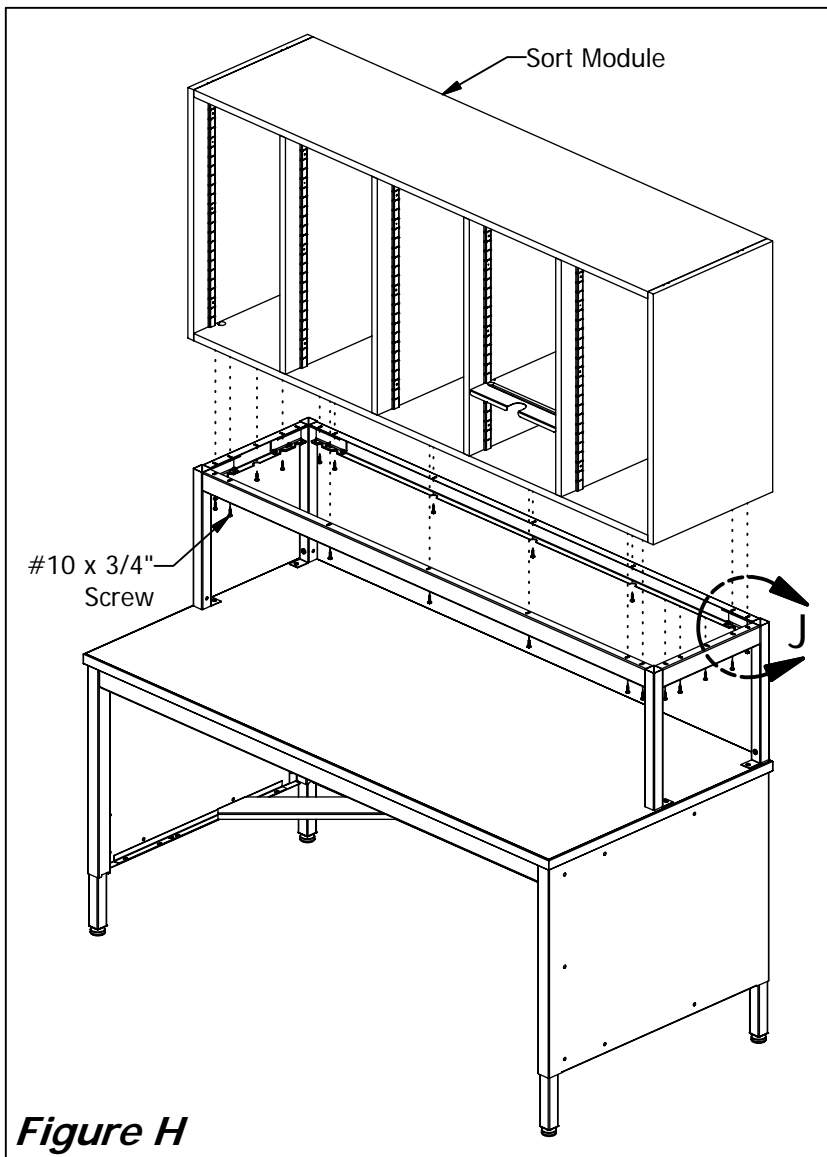
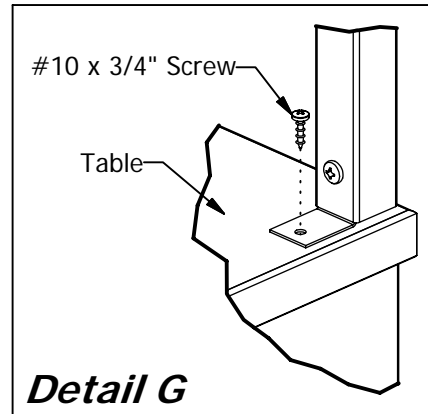

Step 5: OPTIONAL SORT MODULE
Secure Sort Module to Riser with #10 x 3/4" Wood Screws. See *Figure H* & *Detail J*.

For assembly assistance,
please call 1-866-217-0330.